



# **STRUCTURAL DESIGN**

## **Earthquake Engineering**

### **PART C: Assessment and Retrofitting of Existing Structures**

*Prof. Stephanos E. Dritsos, University of Patras, Greece.*

*Pisa, March 2015*



# CONTENT

- **Introduction**
- **Performance Levels or Damage Levels**
- **Elements' Behaviour**
- **Documentation**
- **Methods of Analysis**
- **Seismic Strengthening Strategies - Methods of Strengthening the Whole Structure**
- **Composite Elements**



# INTRODUCTION

## European Standard (EN) for the Design

### **EN 1990 Eurocode 0:**

**Basis of Structural Design**

### **EN 1991 Eurocode 1:**

**Actions on structures**

### **EN 1992 Eurocode 2:**

**Design of concrete structures**

### **EN 1993 Eurocode 3:**

**Design of steel structures**

### **EN 1994 Eurocode 4:**

**Design of composite steel and concrete structures**

### **EN 1995 Eurocode 5:**

**Design of timber structures**

### **EN 1996 Eurocode 6:**

**Design of masonry structures**

### **EN 1997 Eurocode 7:**

**Geotechnical design**

### **EN 1998 Eurocode 8:**

**Design of structures for earthquake resistance**

### **EN 1999 Eurocode 9:**

**Design of aluminium structures**

## Eurocode 8- Design of structures for earthquake resistance

- 1: EN1998-1      *General rules, seismic actions and rules for buildings*
- 2: EN1998-2                      *Bridges*
- 3: EN1998-3      *Assessment and retrofitting of buildings*
- 4: EN1998-4                      *Silos, tanks and pipelines*
- 5: EN1998-5      *Foundations, retaining structures and geotechnical aspects*
- 6: EN1998-6                      *Towers, masts and chimneys*

# CODE ENVIRONMENT

## EUROPE

## U.S.A.

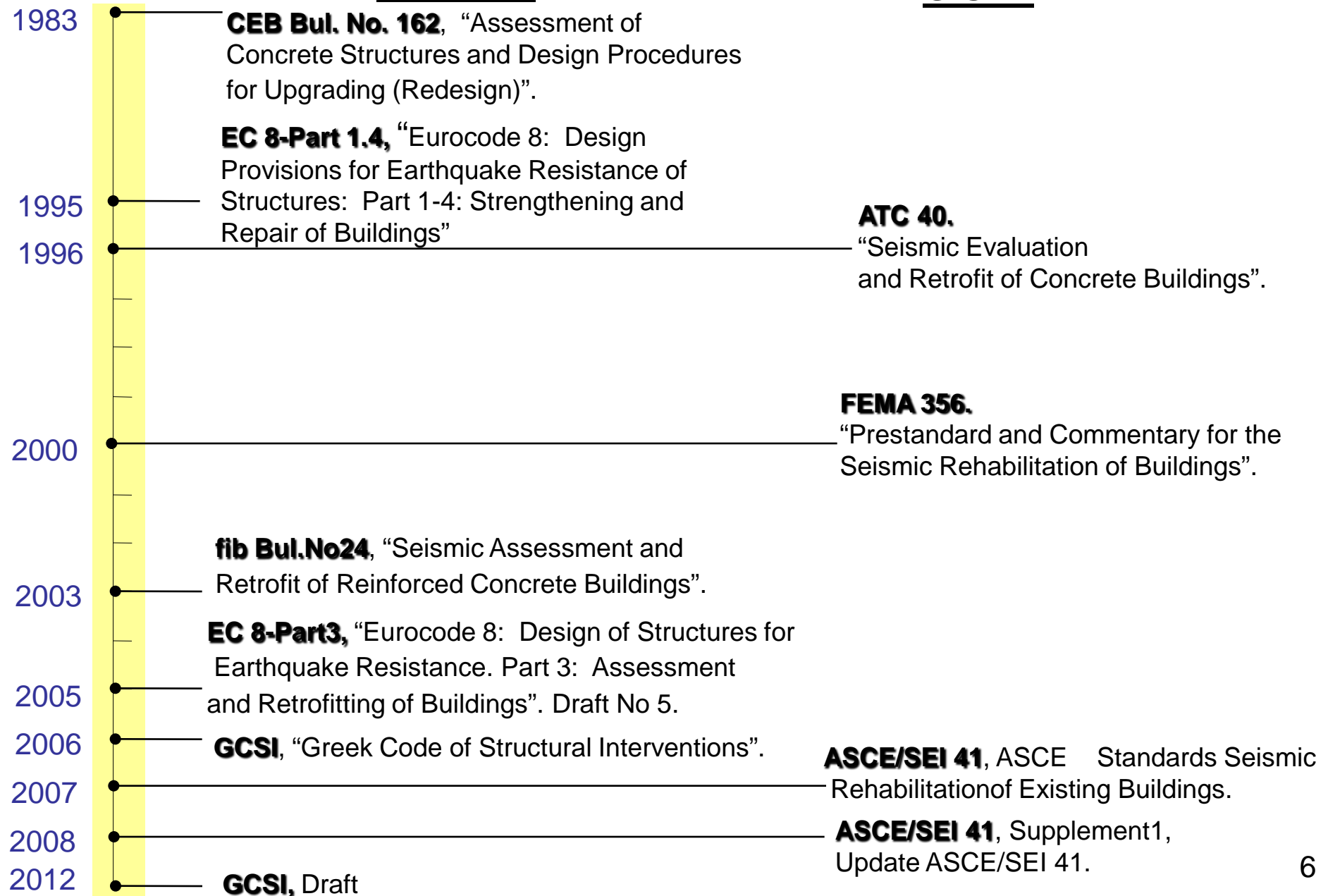

# WEAKNESSES OF EXISTING OLD STRUCTURES UNDER SEISMIC ACTIONS

- (a) The structural system of many old buildings was designed with architectural excesses. Lack of regularity (geometry, strength or stiffness) in plan or in elevation.
- (b) A number of approximations and simplifications were adopted in the analysis. Computers were not in use, 3D analysis was impossible, 2D rarely used. Beams and columns were considered independent elements.
- (c) Critical matters concerning the behaviour of structures under earthquake actions were ignored.
  - Ductility
  - Capacity design
  - Inadequate code provisions for detailing of concrete elements (minimum stirrups, lower limit for compressive reinforcement, upper limit for tensile reinforcement)
- (d) Design for seismic actions much lower than that now accepted for new structures.

**ESTIMATED SEISMIC CAPACITY OF CONCRETE BUILDINGS:  
OLD/NEW  $\simeq$  1/3**

# QUESTIONS

- Which structures have the priority to be strengthened and how to identify them?
- Is it possible (or is it worth) strengthening these structures and to what extent?  
Is this preferable when compared to the demolition and reconstruction solution?
- What resources (materials, methods, techniques) are available to intervene and under what standards are they to be applied?
- Which is the best method of intervention in a specific structure?
- Which is the design framework to assess the seismic capacity of an existing structure and document choices for retrofitting or strengthening?
- What are the quality control procedures for intervention works?



# REDESIGN A MUCH MORE COMPLICATED ISSUE THAN THE DESIGN OF NEW STRUCTURES

- Limited knowledge, poorly documented for the subject
- Lack of codes or other regulations
- The configuration of the structural system of an existing structure may not be permitted. However it exists
- High uncertainty in the basic data of the initial phase of documentation.  
Hidden errors or faults
- Use of new materials which are still under investigation!
- Low (or negative) qualifications or experience of workmanship

# Why we need a new design framework in addition to the existing one for new structures?

## Existing Structures:

(a) Reflect the state of knowledge at the time of their construction

(b) May contain hidden gross errors

(c) May have been stressed in previous earthquakes

(or other accidental actions) with unknown effects

→ Structural assessment and redesign of an existing structure due to a structural intervention are subjected to a different degree of uncertainty than the design of a new structure →

**Different material and structural safety factors** are required

→ **Different analysis procedures** may be necessary depending on the completeness and reliability of available data

Usually, analytical procedures (or software) used for the design of new structures are not suitable to assess existing structures. New structures designed according to new codes necessarily fulfil specific code requirements for being analysed acceptably with conventional analytical procedures, e.g. linear elastic analysis



## THREE MAIN OBJECTIVES

- Assess the seismic capacity of an existing structure
- Decide the necessary intervention work
- Design the intervention work

# ASSESSMENT PROCEDURE

## 1<sup>st</sup> stage

Document the existing structure

## 2<sup>nd</sup> stage

Assessment of the (seismic) capacity of the structure

## 3<sup>rd</sup> stage

Decide if structural intervention required



## 4<sup>th</sup> stage

Design the structural intervention

## 5<sup>th</sup> stage

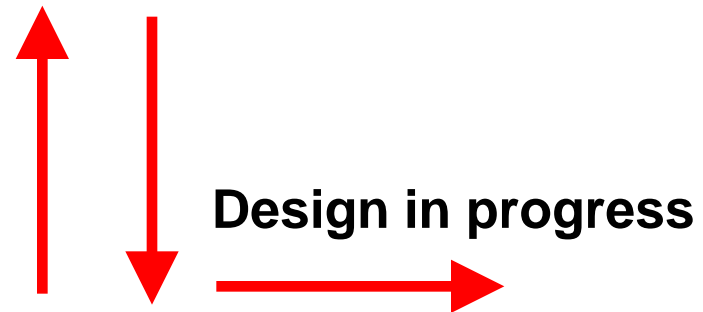
Construct the intervention work





# **PERFORMANCE LEVELS OR DAMAGE LEVELS**

# What is failure?

Action effects > Resistance

- Distinguishing elements for “Ductile” and “Brittle”

Brittle: Verified in terms of forces (known as M, N, V)

Ductile: Verified in terms of deformation

Let  $M_{Rd} = 150 \text{ KNm} < M_{sd} = 200 \text{ KNm}$

In a study of a new building this is never accepted

However in an existing building this is very possible to occur

**Questions:** What level of damage will there be?

What are the consequences?

Is this acceptable?

# Damage Levels

## Performance Levels or Limit States (LS)

### LS Level A Limitation Damage (DL)

➔ **Immediate Occupancy** (other Codes e.g. FEMA): Minimal damage, elements have not substantially yielded

### LS Level B of Significant Damage (SD)

➔ **Life Safety** (other Codes e.g. FEMA): Building with serious damage accepted as the design of new buildings

### LS Level C of Near Collapse (NC)

➔ **Collapse prevention** (other Codes e.g. FEMA): Extensive and serious or severe damage, building is very close to collapse

# PERFORMANCE LEVELS

Acceptable **Performance Levels** or **Level of Protection** (e.g. **State of Damage**) of the Structure:

## **Level A: Immediately Occupancy (IO) or Damage Limitation (DL)**

- Very light damage
- Structural elements retain their strength and stiffness
- No permanent drifts
- No significant cracking of infill walls
- Damage could be economically repaired

## **Level B: Life Safety (LS) or Significant Damage (SD)**

- Significant damage to the structural system however retention of some lateral strength and stiffness
- Vertical elements capable of sustaining vertical loads
- Infill walls severally damaged
- Moderate permanent drifts exist
- The structure can sustain moderate aftershocks
- The cost of repair may be high. The cost of reconstruction should be examined as an alternative solution



# PERFORMANCE LEVELS

## **Level C: Collapse Prevention (CP) or Near Collapse (NP)**

- Structure heavily damaged with low lateral strength and stiffness
- Vertical elements capable of sustaining vertical loads
- Most non-structural components have collapsed
- Large permanent drifts
- Structure is near collapse and possibly cannot survive a moderate aftershock
- Uneconomical to repair. Reconstruction the most probable solution

# PERFORMANCE LEVELS

Gradual pushing (static horizontal loading) of structure up to failure

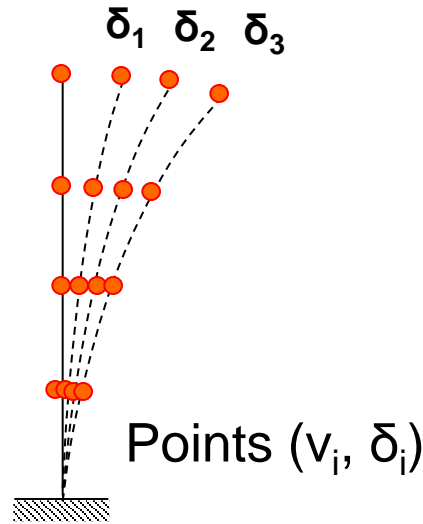
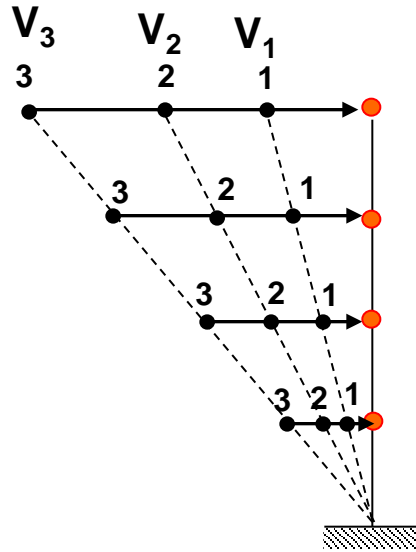

(Base shear)

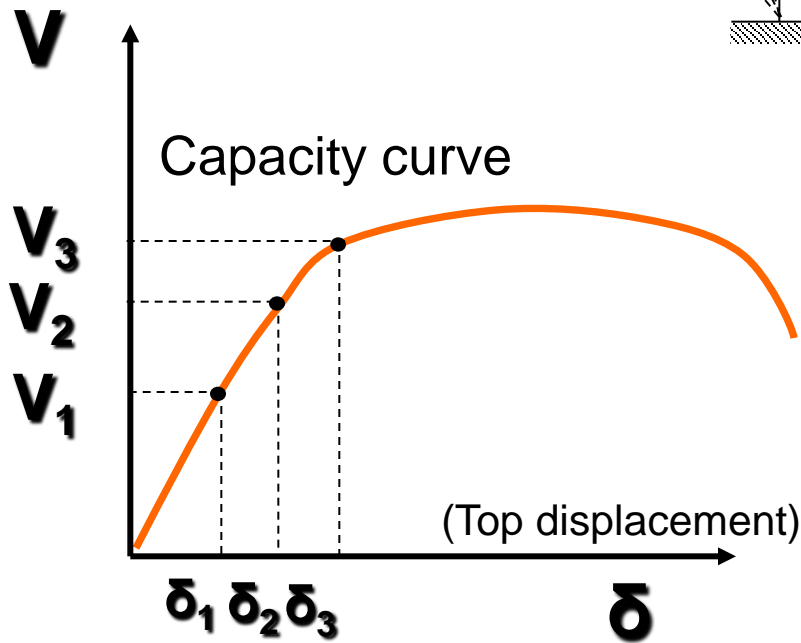

**V** Performance Levels

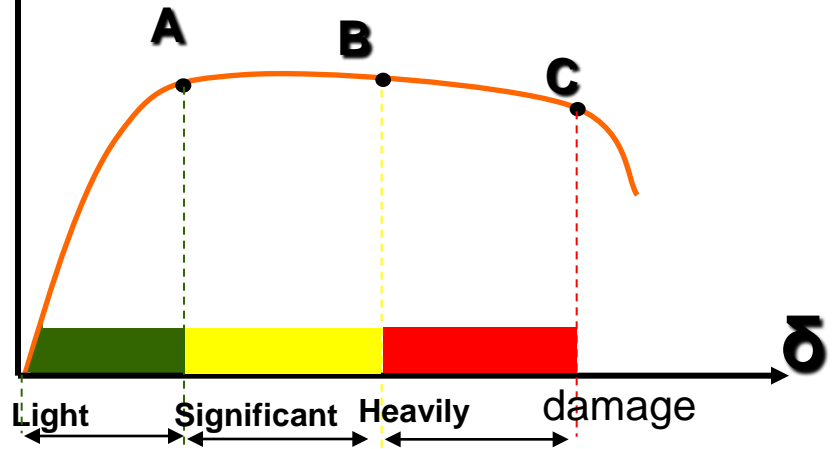

# SEISMIC ACTIONS

What is the design seismic action?

Which return period should be selected for the seismic action?

Should this be the same as for new structures?

## Design Levels

Occurrence probability in 50 years	Collapse prevention (CP)	Life safety (LS)	Immediately occupancy (IO)
2% Return period 2475 years	CP <sub>2%</sub>	LS <sub>2%</sub>	DL <sub>2%</sub>
10% Return period 475 years	CP <sub>10%</sub>	LS <sub>10%</sub>	DL <sub>10%</sub>
20% Return period 225 years	CP <sub>20%</sub>	LS <sub>20%</sub>	DL <sub>20%</sub>
50% Return period 70 years	CP <sub>50%</sub>	LS <sub>50%</sub>	DL <sub>50%</sub>



Usual design of new buildings



Design of important structures (remain functional during earthquake)



Minimum acceptable seismic action level

Instead, do nothing due to economic, cultural, aesthetic and functional reasons

## Performance Levels according to the Greek Code of Structural Interventions (Greek.C.S.I.)

Seismic activity probability of exceedance in the conventional design life of 50 years	Minimal Damage (Immediate Occupancy)	Severe Damage (Life Safety)	Collapse Prevention
<b>10%</b> (Seismic actions according to EK8-1)	<b>A1</b>	<b>B1</b>	<b>Γ1</b>
<b>50%</b> (Seismic actions = 0.6 x EK8-1)	<b>A2</b>	<b>B2</b>	<b>Γ2</b>

The public authority defines when the 50% probability is not permitted



# **ELEMENT'S BEHAVIOUR**

# ELEMENT BEHAVIOR

## Ductile

Flexure controlled

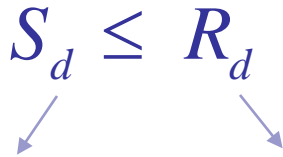
$$S_d \leq R_d$$

deformation demand

deformation capacity

## Brittle

Shear controlled

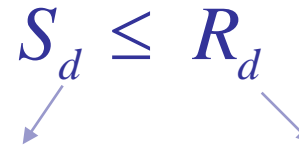
$$S_d \leq R_d$$

strength demand

strength capacity

## Seismically Primary

## Seismically Secondary

### “Secondary” seismic element

- More damage is acceptable for the same Performance Level
- Considered not participating in the seismic action resisting system.  
Strength and stiffness are neglected
- Able to support gravity loads when subjected to seismic displacements

# REINFORCED CONCRTE STRUCTURES

## Element's Capacity Curve

$$m = \frac{\theta_d}{\theta_y}$$

$$K = EI_{ef} = \frac{M_y \cdot L_s}{3\theta_y}$$

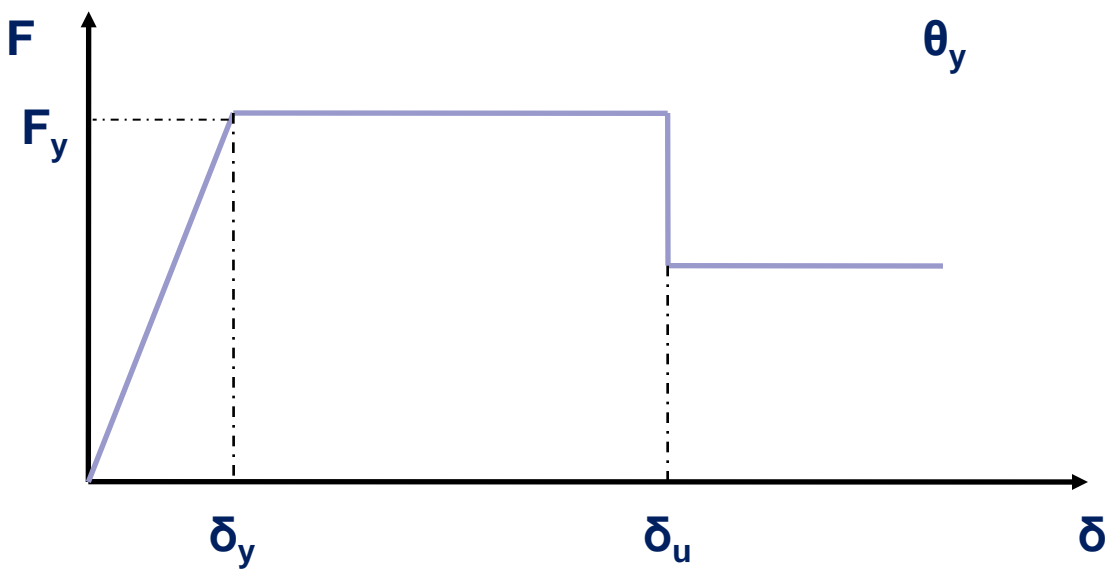
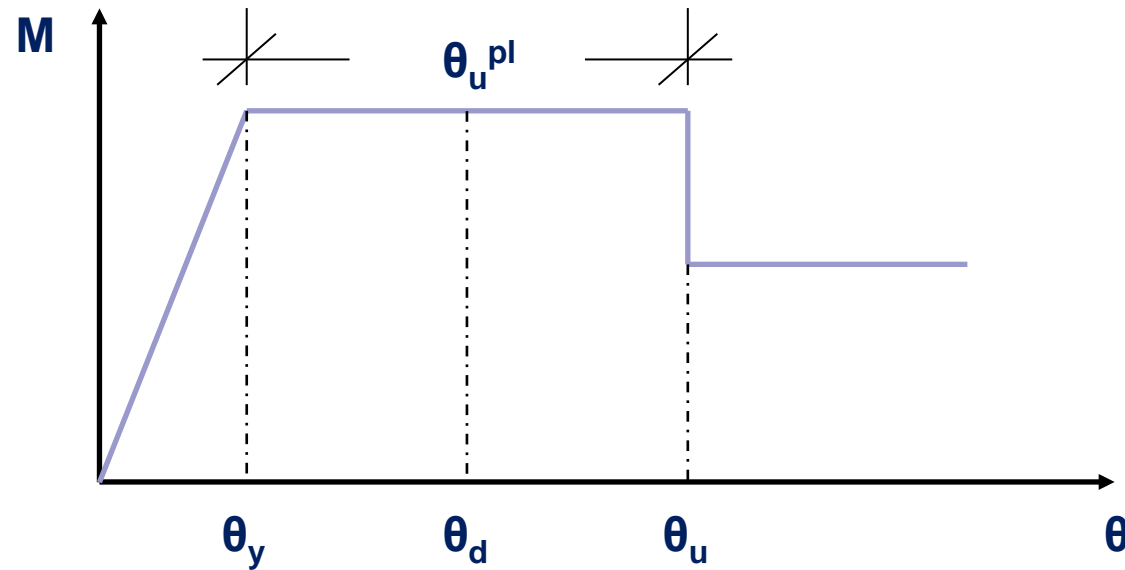

$$K = \frac{F_y}{\delta_y}$$

# Element's Capacity

Chord rotation at yielding of a concrete element

$$\theta_y = (1/r)_y \frac{L_s + a_V z}{3} + 0,0014 \left( 1 + 1,5 \frac{h}{L_s} \right) + \frac{(1/r)_y d_b f_y}{8\sqrt{f_c}} \quad \text{Beams and columns}$$

$$\theta_y = (1/r)_y \frac{L_s + a_V z}{3} + 0,0013 + \frac{(1/r)_y d_b f_y}{8\sqrt{f_c}} \quad \text{Walls of rectangular, T- or barbell section}$$

The value of the total chord rotation capacity of concrete elements under cyclic loading

$$\theta_{um} = 0,016 \cdot (0,3^V) \left[ \frac{\max(0,01; \omega')}{\max(0,01; \omega)} f_c \right]^{0,225} (\alpha_s)^{0,35} 25 \left( \frac{\alpha \rho_s f_{yw}}{f_c} \right) (1,25^{100} \rho_d)$$

The value of the plastic part of the chord rotation capacity of concrete elements under cyclic loading

$$\theta_{um}^{pl} = \theta_u - \theta_y = 0,0145 (0,25^V) \left[ \frac{\max(0,01; \omega')}{\max(0,01; \omega)} \right]^{0,3} (f_c)^{0,2} (\alpha_s)^{0,35} 25 \left( \frac{\alpha \rho_s f_{yw}}{f_c} \right) (1,275^{100} \rho_d)$$



# ELEMENT'S SAFETY VERIFICATION

Inequality of Safety

$$S_d \leq R_d$$

$S_d$  is the design action effect

$R_d$  is the design resistance

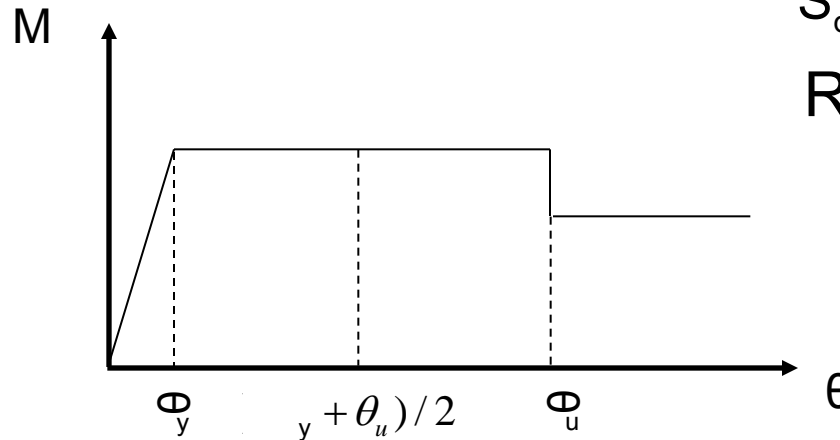

For brittle components/mechanisms (e.g. shear)

$S_d, R_d$  concern forces

For ductile components/mechanisms (e.g. flexural)

$S_d, R_d$  concern deformations,  $\Phi_{sd}, \Phi_{Rd}$

(G.S.I. Code)

A Level (IO)

$$\Phi_{Rd} = \theta_y$$

B Level (LS)

$$\Phi_{Rd} = \frac{1}{\gamma_{Rd}} \frac{\theta_y + \theta_u}{2}$$

“primary” elements  $\gamma_{Rd} = 1,8$

$$\Phi_{Rd} = \frac{\theta_u}{\gamma_{Rd}}$$

“secondary” elements  $\gamma_{Rd} = 1,8$

C Level (NC)

$$\Phi_{Rd} = \frac{\theta_u}{\gamma_{Rd}}$$

$\gamma_{Rd} = 1,8$  for “primary” elements

$\gamma_{Rd} = 1,0$  for “secondary” elements

# ELEMENT'S SHEAR CAPACITY

## Beams and Columns

$$V_R = \frac{h-x}{2L_s} \min(N; 0,55 A_c f_c) + \left(1 - 0,05 \min(5; \mu_{\theta}^{pl})\right) \left[0,16 \max(0,5; 100 \rho_{tot}) (1 - 0,16 \min(5; \alpha_s)) \sqrt{f_c} A_c + V_w\right]$$

$$V_w = \rho_w b_w z f_{yw}$$

rectangular web cross section

$$V_w = \frac{\pi}{2} \frac{A_{sw}}{s} f_{yw} (D - 2c)$$

circular cross section

## Shear Walls

$$V_{R,max} = 0,85 \left(1 - 0,06 \min(5; \mu_{\theta}^{pl})\right) \left(1 + 1,8 \min(0,15; \frac{N}{A_c f_c})\right) \left(1 + 0,25 \max(1,75; 100 \rho_{tot})\right) \left(1 - 0,2 \min(2; a_s)\right) \sqrt{f_c} b_w z$$

## Short Columns ( $LV/h \leq 2$ )

$$V_{R,max} = \frac{4}{7} \left(1 - 0,02 \min(5; \mu_{\theta}^{pl})\right) \left(1 + 1,35 \frac{N}{A_c f_c}\right) \left(1 + 0,45 (100 \rho_{tot})\right) \sqrt{\min(40; f_c)} b_w z \sin 2\delta$$



# DOCUMENTATION

# ASSESSMENT PROCEDURE

## 1<sup>st</sup> stage

Document the existing structure

## 2<sup>nd</sup> stage

Assessment of the (seismic) capacity of the structure

## 3<sup>rd</sup> stage

Decide if structural intervention required

## 4<sup>th</sup> stage

Design the structural intervention

## 5<sup>th</sup> stage

Construct the intervention work

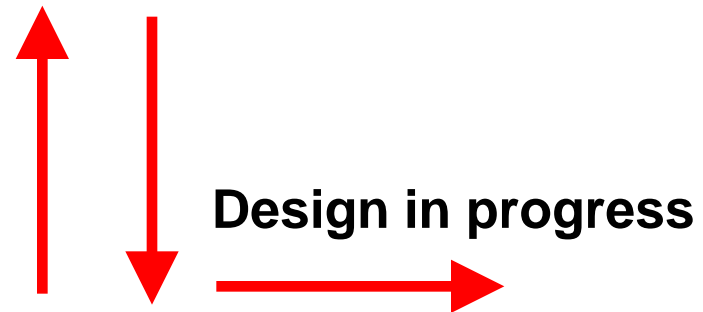

# Documentation of an Existing Structure



- Strength of materials
- Reinforcement
- Geometry (including foundation)
- Actual loads
- Past damage or “wear and tear” or defects

➔ Knowledge Levels (KL)

➔ Confidence factors (Other safety factors for existing materials and elements)

➔ New safety factors for new materials

## Knowledge Levels (KL)

- Full Knowledge  KL3
- Normal Knowledge  KL2
- Limited Knowledge  KL1
- Inadequate: May allowed only for secondary elements

# DOCUMENTATION

## Knowledge Levels and Confidence Factors

KL<sub>1</sub>: Limited Knowledge

KL<sub>2</sub>: Normal Knowledge

KL<sub>3</sub>: Full Knowledge

Knowledge Level	Geometry	Details	Materials	Analysis	CF
KL1	From original outline construction drawings with sample <b>visual</b> survey <b>or</b> from <b>full</b> survey	Simulated design in accordance with relevant practice <b>and</b> from <b>limited in-situ</b> inspection	Default values in accordance with standards of the time of construction <b>and</b> from <b>limited in-situ</b> testing	LF-MRS	CF <sub>KL1</sub> = 1.35
KL2		From incomplete original detailed construction drawings with <b>limited in-situ</b> inspection <b>or</b> from <b>extended in-situ</b> inspection	From original design specifications with <b>limited in-situ</b> testing <b>or</b> from <b>extended in-situ</b> testing	All	CF <sub>KL2</sub> = 1.20
KL3		From original detailed construction drawings with <b>limited in-situ</b> inspection <b>or</b> from <b>comprehensive in-situ</b> inspection	From original test reports with <b>limited in-situ</b> testing <b>or</b> from <b>comprehensive in-situ</b> testing	All	CF <sub>KL3</sub> = 1.00

# Knowledge Levels (KL) for Materials Data

## Concrete (G.C.S.I.)

- Assessment methods  $f_c$ :
  - Combination of indirect (non-destructive) methods.
  - Calibrate with destructive methods involving taking samples (e.g. cores).
  - Pay attention to correct correlation between destructive and non-destructive methods.
  - Final use of calibrated non-destructive methods throughout the structure
- Required number of specimens
  - Not all together, i.e. spread out over all floors and all components
  - At least 3 cores per alike component per two floors, definitely for the "critical" floor level
- Additional methods (acoustic or Schmidt Hammer or extrusion or rivet for  $f_c < 15$  MPa)
  - Full knowledge/storey: 45% vertical elements/25% horizontal elements
  - Normal knowledge/storey: 30% vertical elements/25% horizontal elements
  - Limited knowledge/storey: 15% vertical elements/7.5% horizontal elements

## Steel

**Visual identification and classification is allowed. In this case, the KL is considered  $KL_2$**



# Knowledge Levels for Details Data

## ■ Data Sources:

1. Data from the original study plans that has proof of implementation
2. Data from the original study plans which has been implemented with a few modifications identified during the investigation
3. Data from a reference statement (legend) in the original study plan
4. Data that has been established and/or measured and/or acquired reliably
5. Data that has been determined indirectly
6. Data that has been reasonably obtained from engineering judgement

# Knowledge Levels for Details Data (G.C.S.I.)

ORIGINAL DESIGN DRAWINGS		DATA ORIGIN		NOTES	DATA								
					TYPE AND GEOMETRY OF FOUNDATION OR SUPERSTRUCTURE			THICKNESS, WEIGHT etc. OF INFILL WALLS, CLADDING, COVERING, etc.			REINFORCEMENT LAYOUT AND DETAILING		
Exist	Do not exist				KL1	KL2	KL3	KL1	KL2	KL3	KL1	KL2	KL3
✓		1	Data that is derived from a drawing of the original design that is proved to have been applied without modification	(1)			✓			✓			✓
✓		2	Data that is derived from a drawing of the original design that has been applied with few modifications	(2)			✓			✓		✓	
✓		3	Data that is derived from a reference (e.g. legend in a drawing of the original design)	(3)	✓			✓			✓		
	✓	4	Data that has been determined and/or measured and/or surveyed reliably	(4)		✓			✓			✓	
	✓	5	Data that has been determined by an indirect but sufficiently reliable manner	(5)	✓			✓			✓		
	✓	6	Data that has been reasonably assumed using the Engineer's judgment	(6)	✓	✓		✓	✓		✓	✓	



# **METHODS OF ANALYSIS**

## METHODS OF ANALYSIS

### In Redesign other analysis methods are required

Elastic analysis methods currently in use (for new buildings) have a reliability under specific conditions to make sure new buildings to be met.

In most cases, these conditions are not met in the old buildings.

# METHODS OF ANALYSIS

Same as those used for design new construction (EC8-Part 1)

- Lateral force analysis (linear)
- Modal response spectrum analysis (linear)
- Non-linear static (pushover) analysis
- Non-linear time history dynamic analysis
- q-factor approach

# PERFORMANCE LEVELS

Gradual pushing (static horizontal loading) of structure up to failure

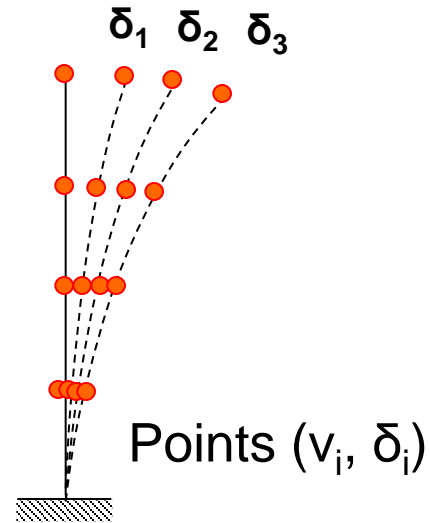
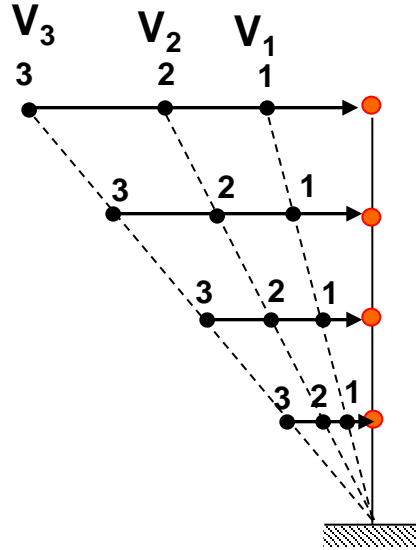

(Base shear)

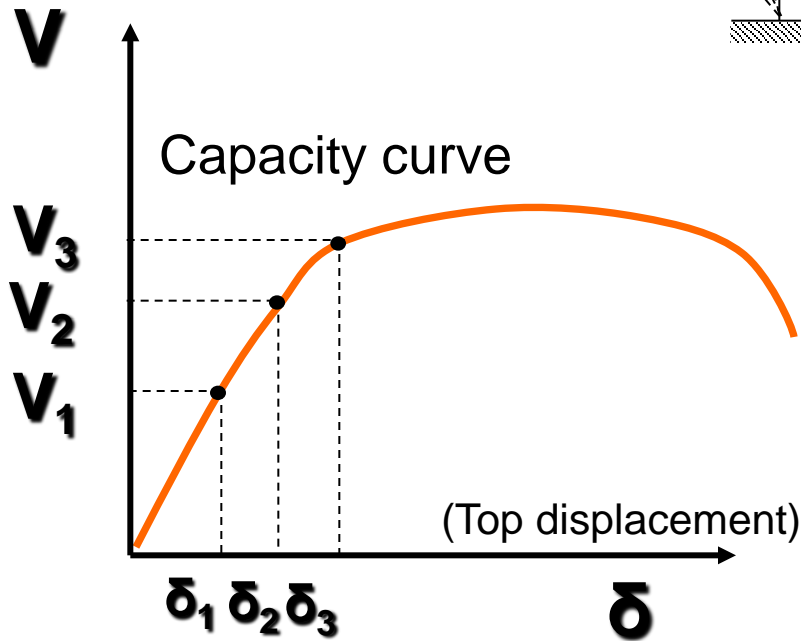

**V** Performance Levels

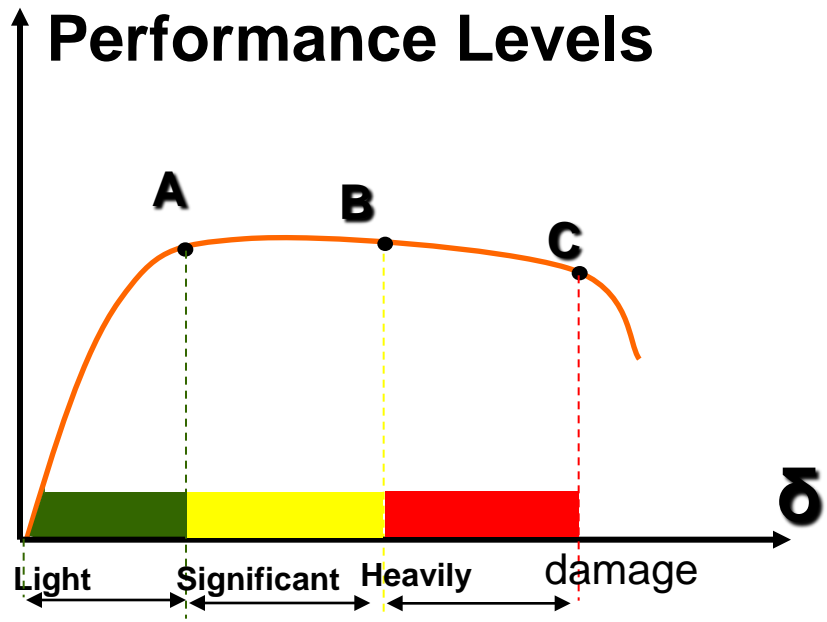

# CAPACITY DEMAND

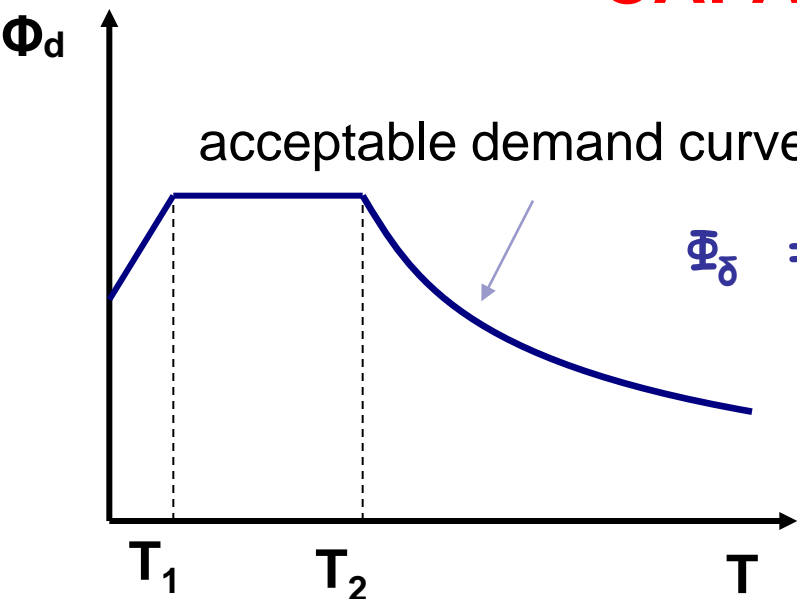

$$\Phi_{\delta} = \frac{T^2}{4\pi^2} \Phi_d g$$

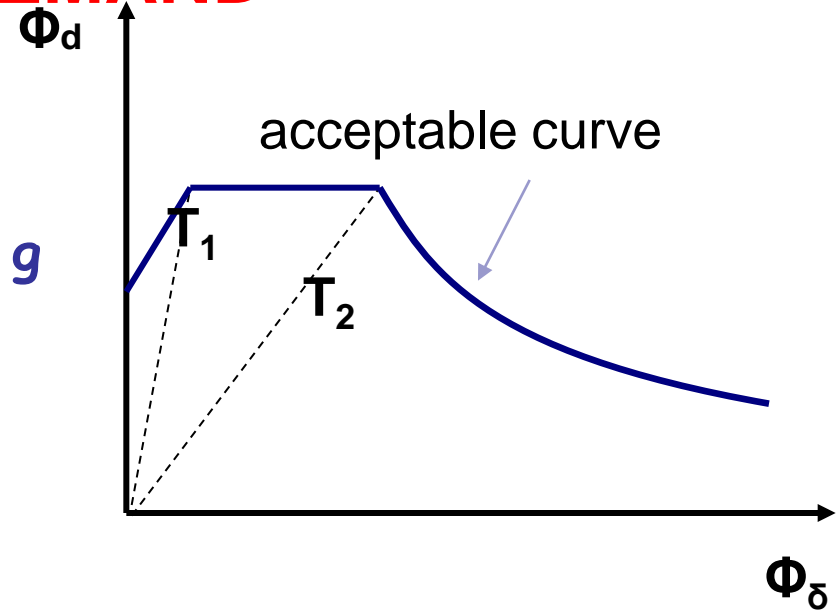

code elastic spectrum

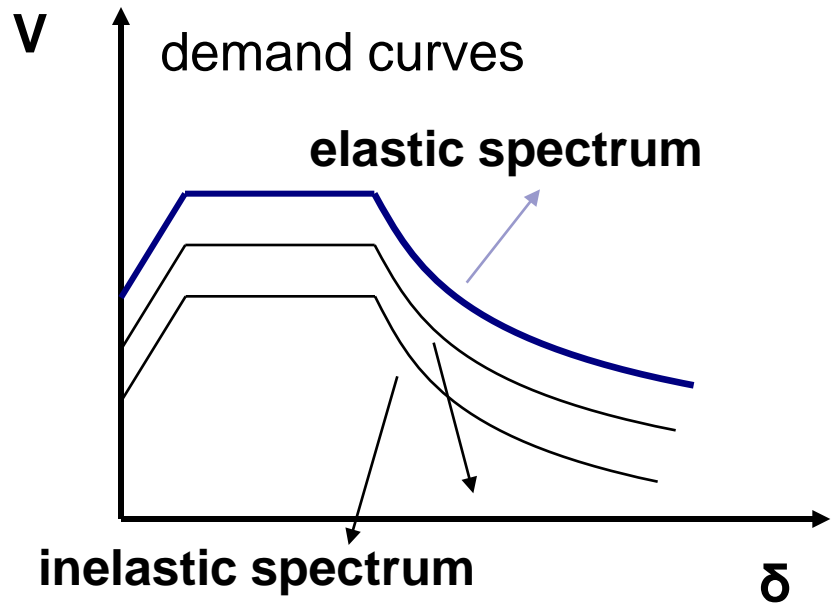

$$V = \alpha \Phi_d W$$



$$\delta = \beta \Phi_{\delta}$$

n	alpha	beta
1	1	1
2	0.90	1.20
5	0.80	1.35

# SAFETY VERIFICATION

## Checking a Structure's Capacity

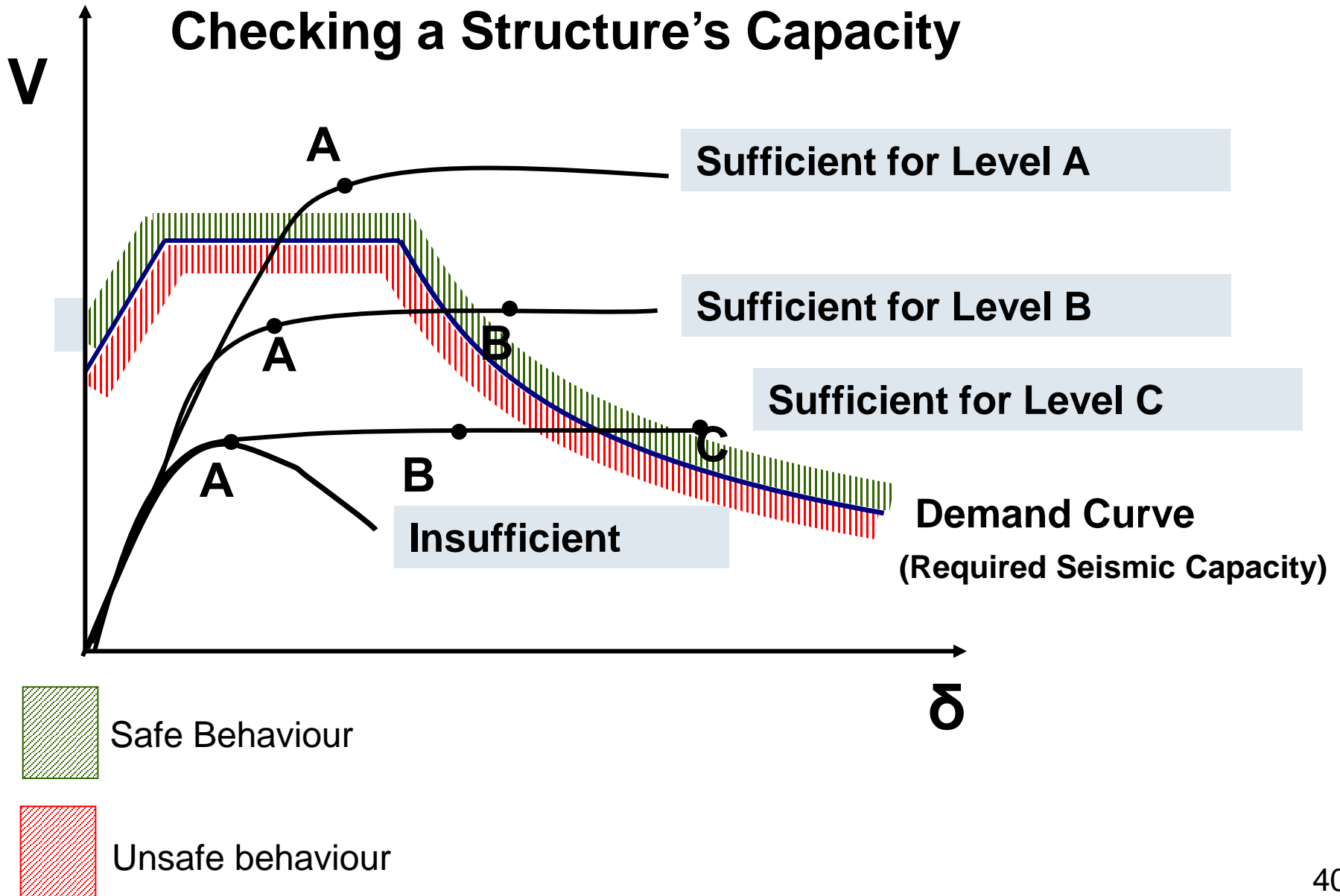





# **Seismic Strengthening Strategies**

## **Methods of Strengthening the Whole Structure**

# SEISMIC STRENGTHENING STRATEGIES

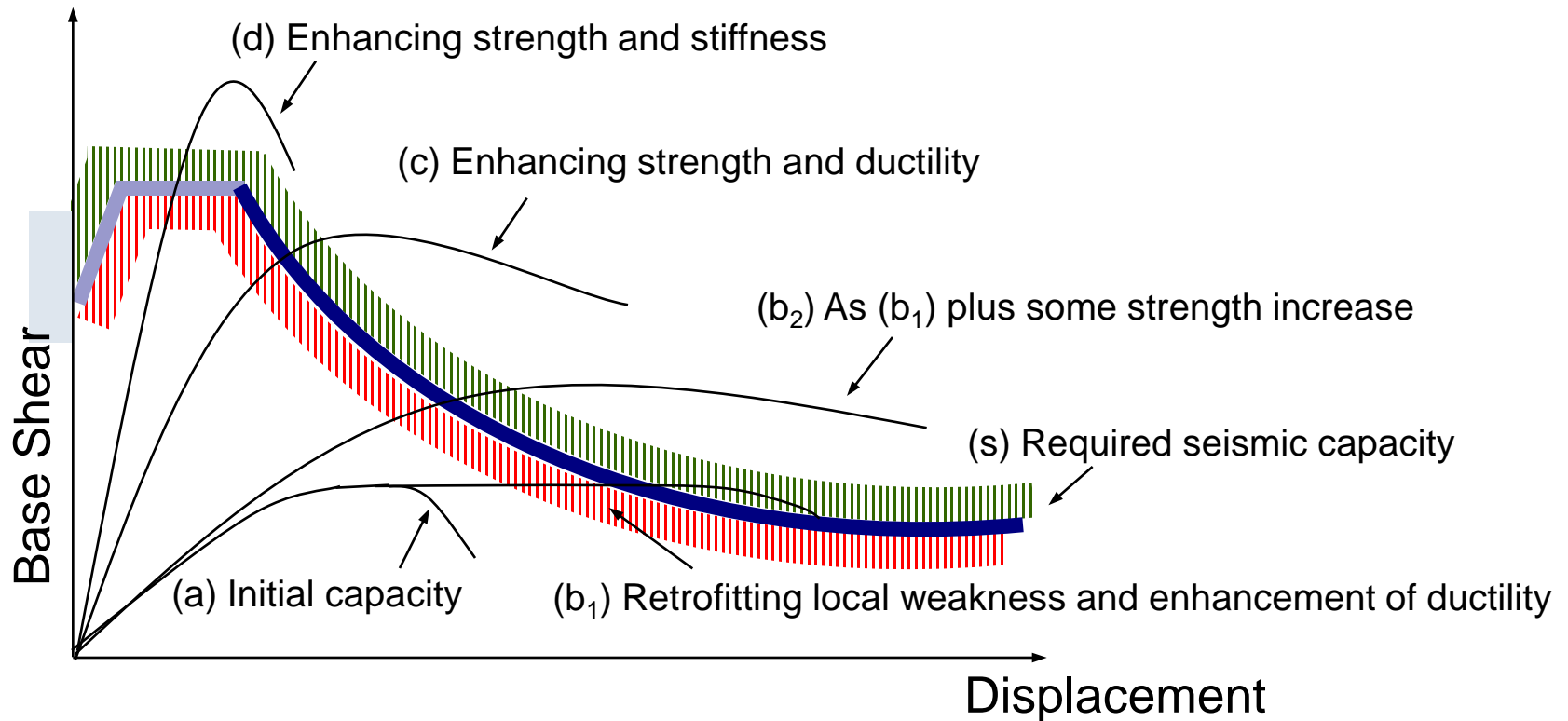

 Safe Design

 Unsafe Design

# SEISMIC STRENGTHENING METHODS

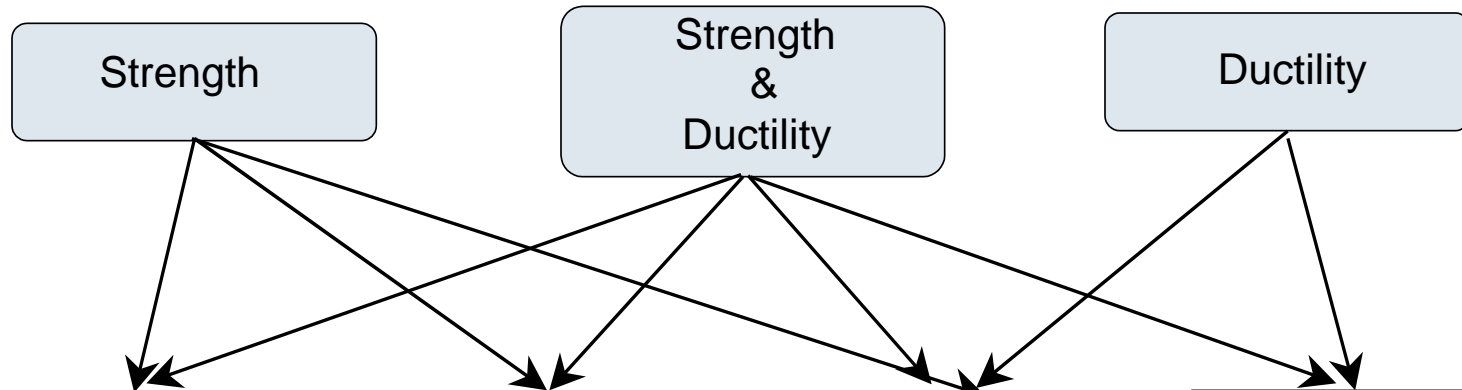

**Add New Walls**  
(a) Infill walls  
(b) Externally attached to the structural system  
**(specific design)**

**Steel or Concrete Bracing**

**Adding RC Wing Walls**

**Jackets**  
(a) of RC  
(b) of steel elements  
(c) of composite materials



Strength & Stiffness

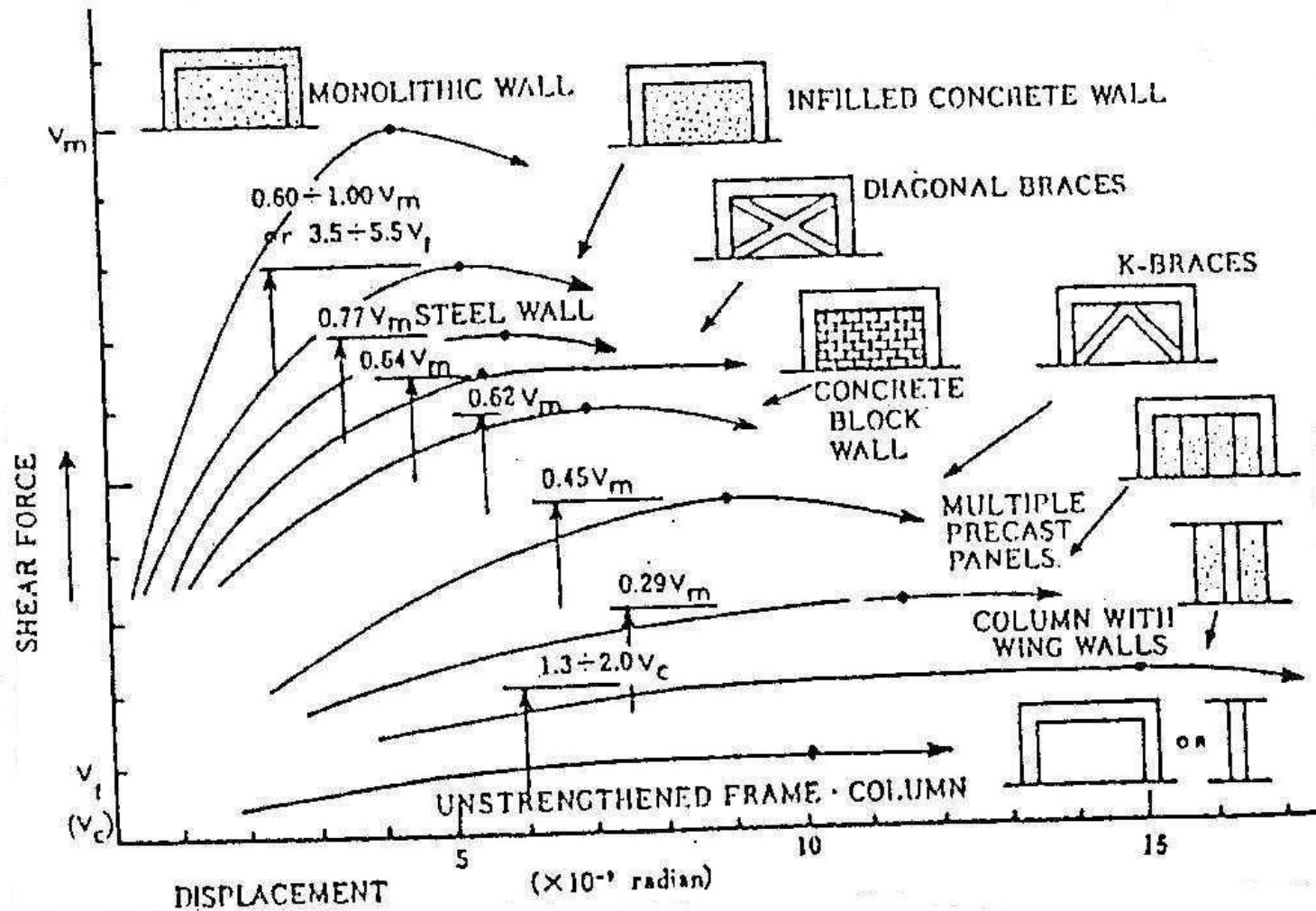

**The relative effectiveness of strengthening**

## Adding Simple Infill

- Addition of walls from:
  - a) Unreinforced or reinforced concrete (cast in situ or prefabricated)
  - b) Unreinforced or reinforced masonry
- No specific requirement to connect infill to the existing frame
- Modelling of infills by diagonal strut
- Low ductility of infill. Recommended  $m \leq 1,5$

### WARNING

Additional shear forces are induced in the columns and beams of the frame

# Strengthening of existing masonry infills

- Reinforced shotcrete concrete layers applied to both sides of the wall
  - Minimum concrete thickness 50 mm
  - Minimum reinforcement ratio  $\rho_{\text{vertical}} = \rho_{\text{horizontal}} = 0,005$

Essential to positively connect both sides by bolting through the wall

No need to connect to existing frame as it is an infill

All new construction must be suitably connected to the existing foundation

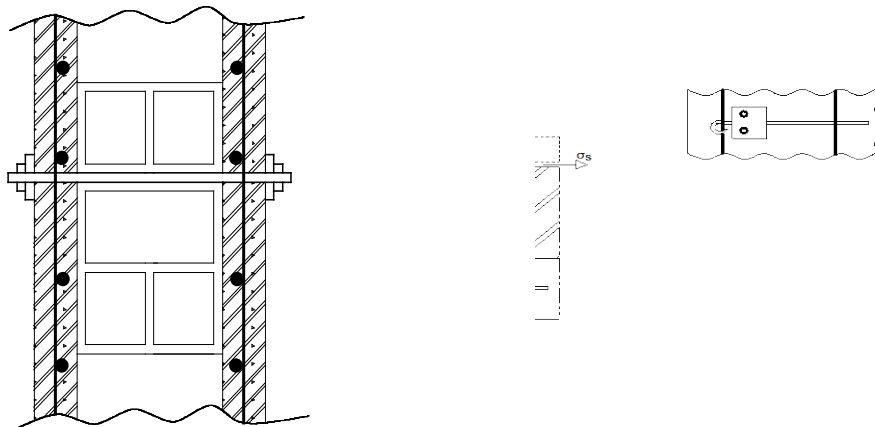

46

# Frame Encasement

Reinforced walls are constructed from one column to another enclosing the frame (including the beam) with jackets placed around the columns. Note, all new construction must be suitably connected to the existing foundation

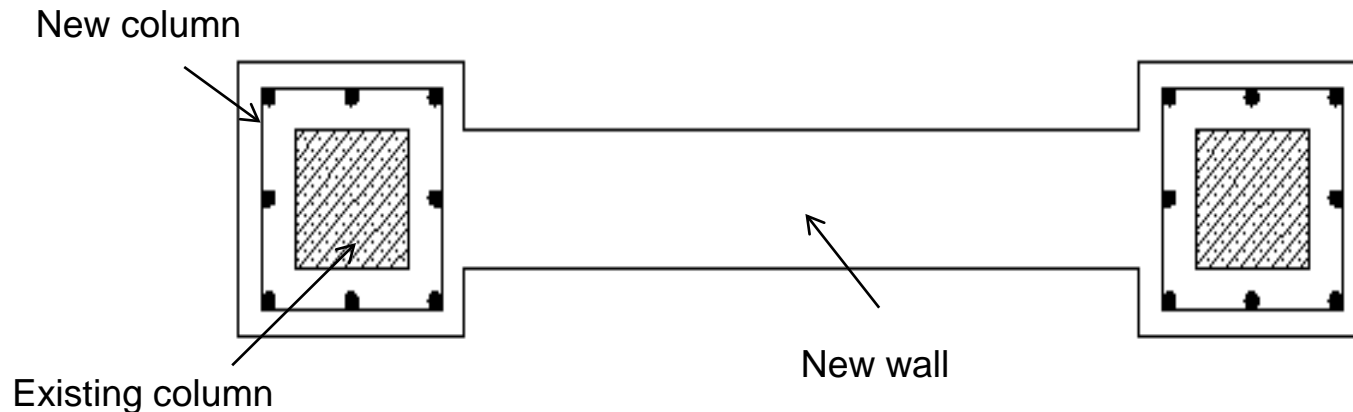
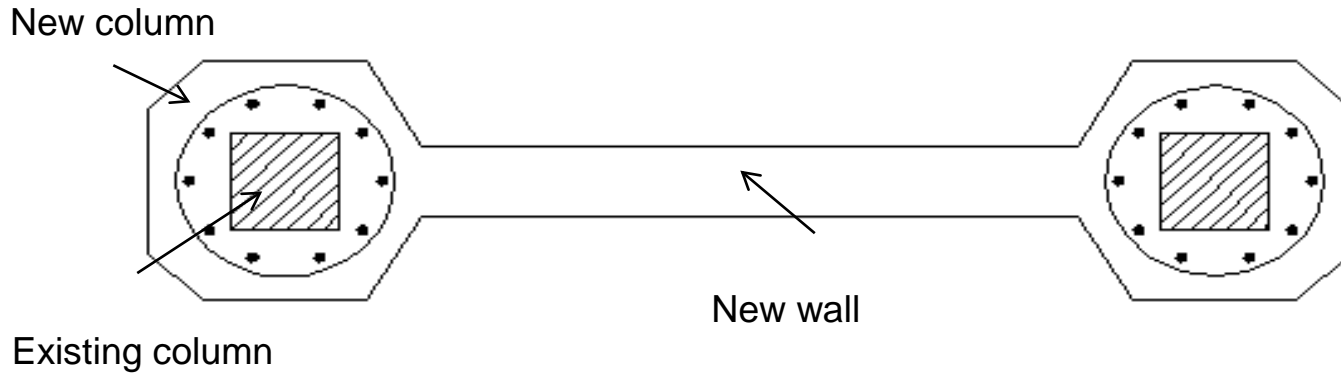

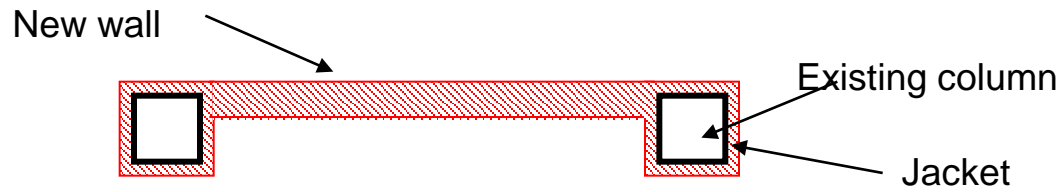
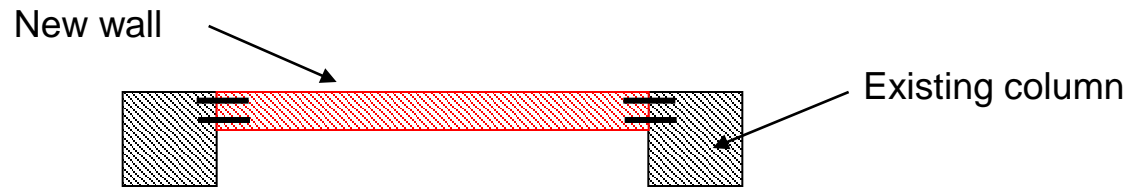

## Infilling new shear walls

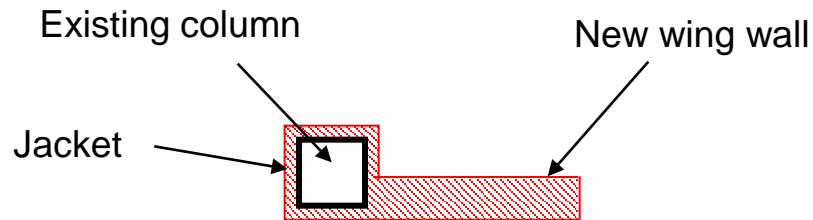
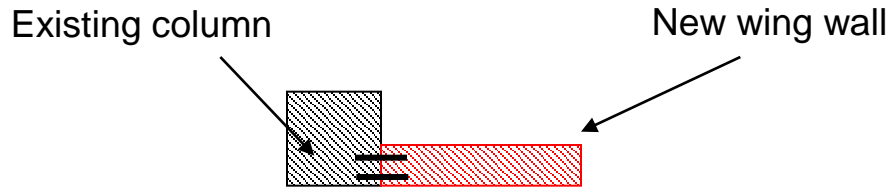

## Addition of new wing walls



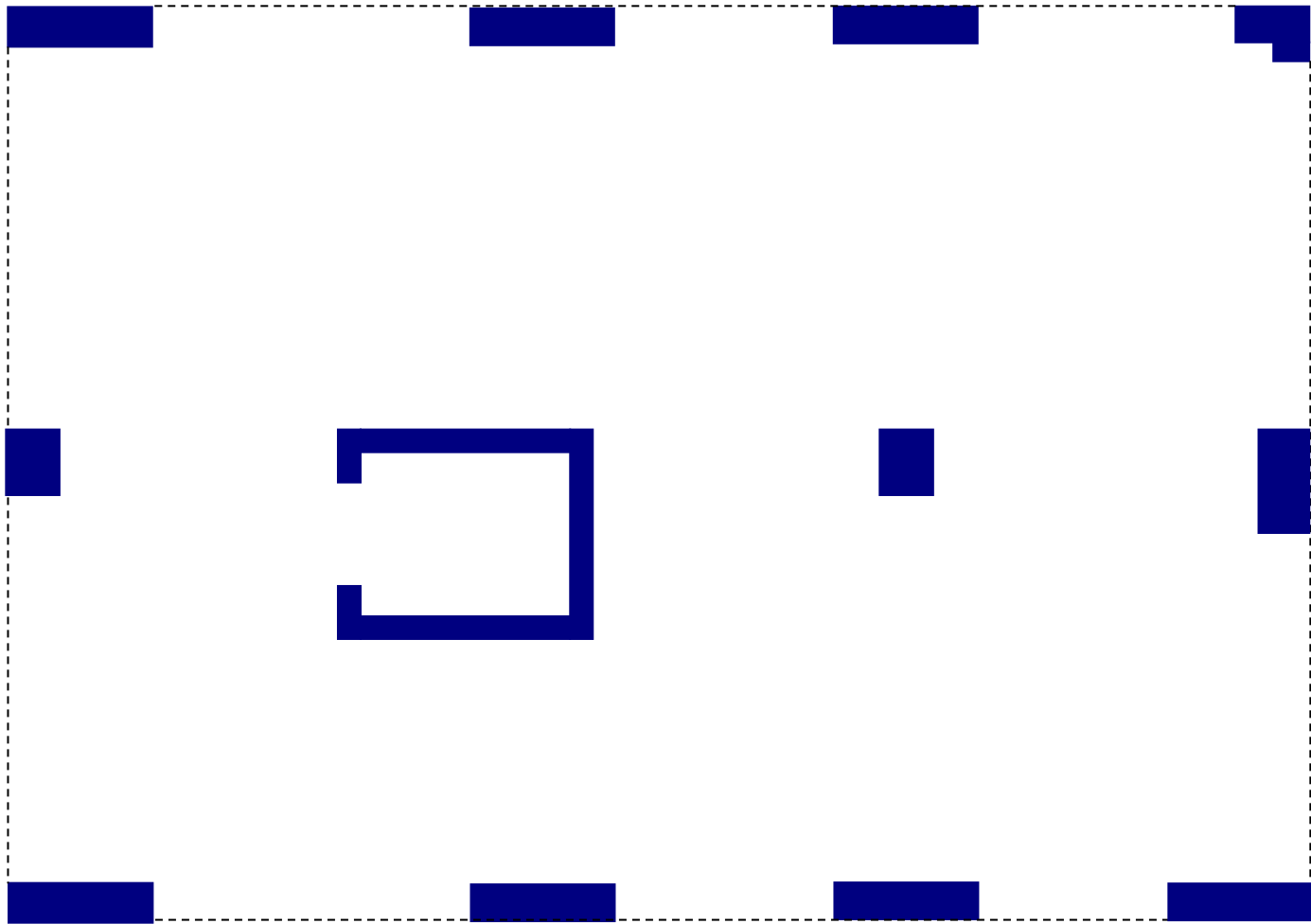

**Existing vertical element configuration (PLAN)**

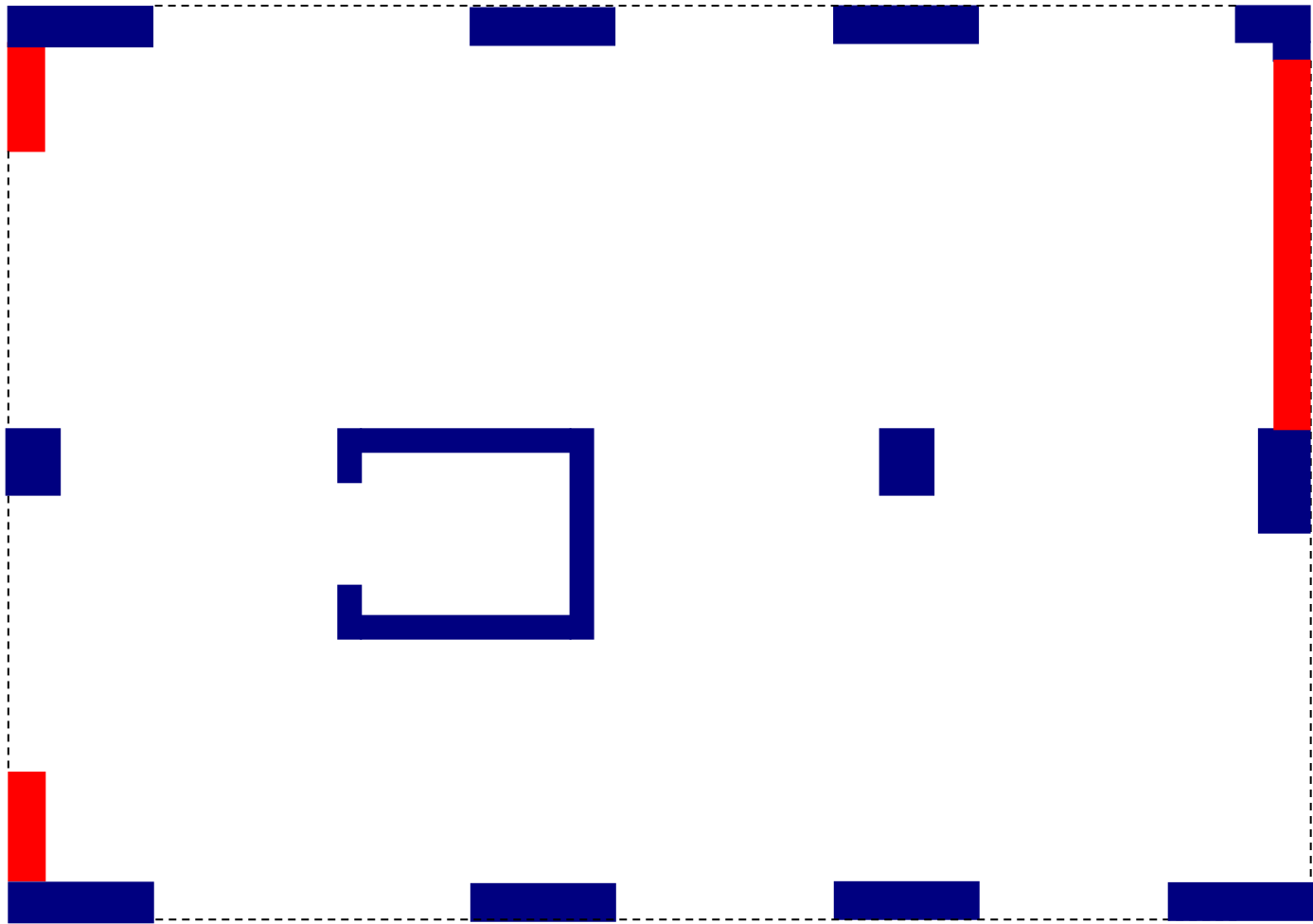

**Strengthening proposal**







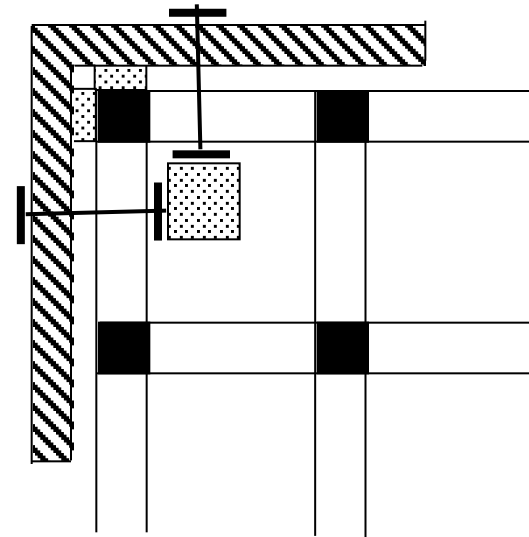
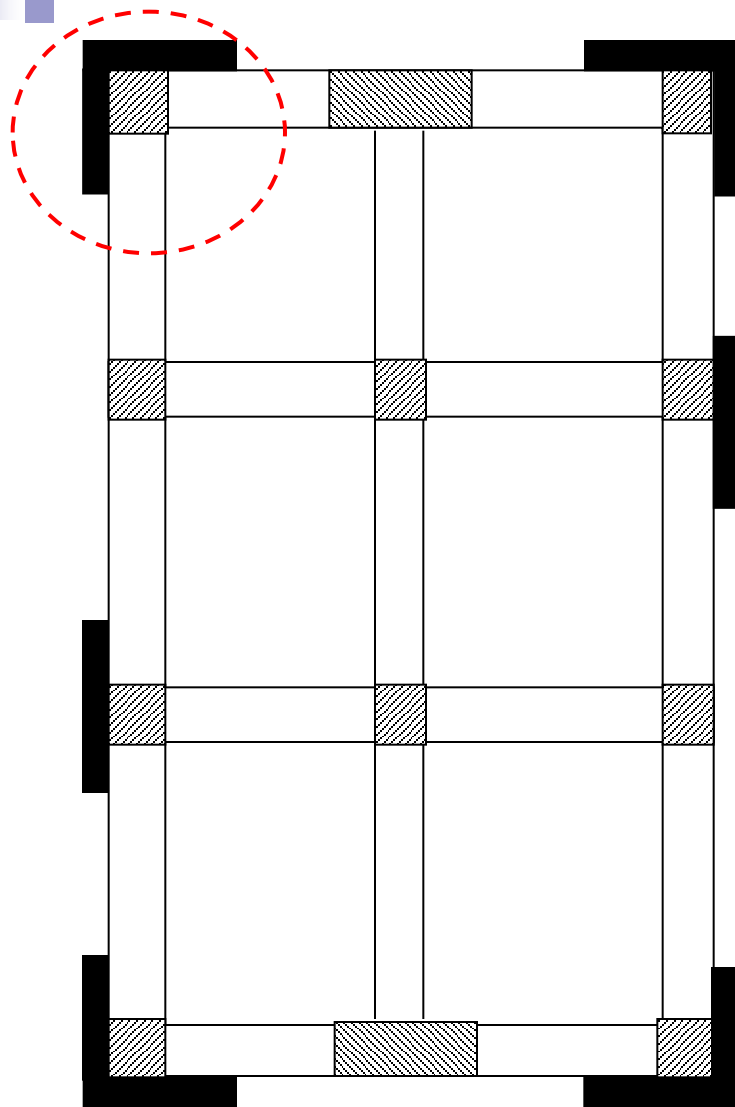

Schematic arrangement of connections between existing building and new wall

## **Addition of new external walls**



**Addition of a bracing system**







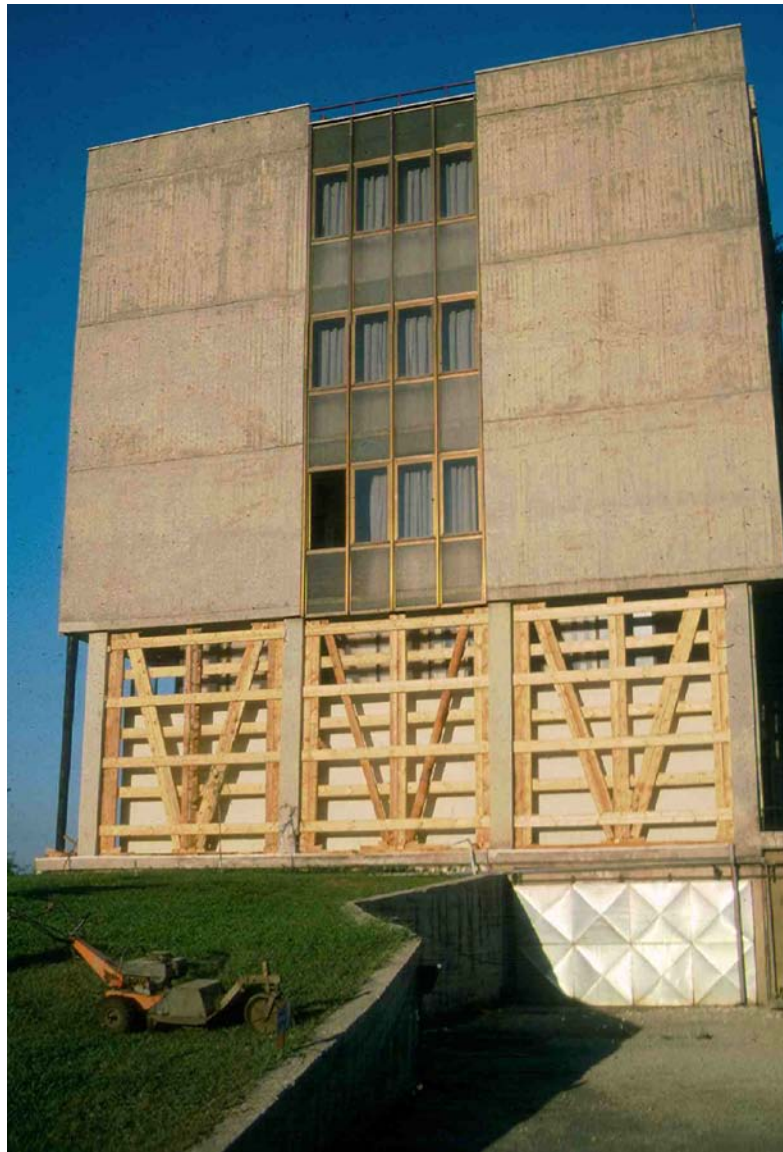

**Temporary support and stiffening of the damaged soft floor**



# COMPOSITE ELEMENTS

**8.1 General requirements**

- Interface verification



**8.2 Interventions for critical regions of linear structural elements**

- Interventions with a capacity objective against flexure with axial force
- Interventions with the objective of increasing the shear capacity
- Interventions with the objective of increasing local ductility
- Interventions with the objective of increasing the stiffness

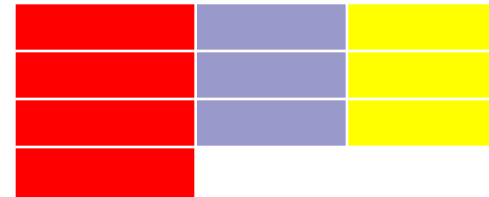

**8.3 Interventions for joints of frames**

- Inadequacy due to diagonal compression in the joint
- Inadequacy of joint reinforcement



**8.4 Interventions for shear walls**

- Interventions with a capacity objective against flexure with axial force
- Interventions with the objective of increasing the shear capacity
- Interventions with the objective of increasing the ductility
- Interventions with the objective of increasing the stiffness

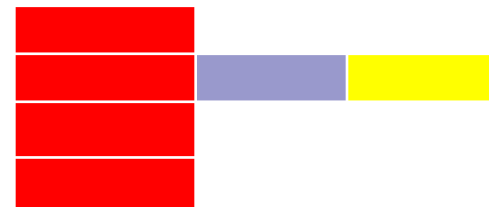

**8.5 Frame encasement**

- Addition of simple “infill”
- Converting frames to shear walls
- Strengthening of existing masonry infill
- Addition of bracing, conversion of frames to vertical trusses

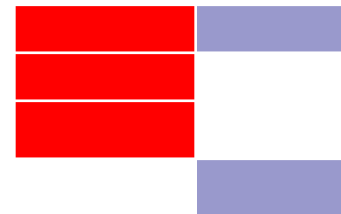

**8.6 Construction of new lateral shear walls**

- Stirrups
- Foundations for new shear walls
- Diaphragms



**8.7 Interventions for foundation elements**



# EXPERIMENTAL WORK (UNIVERSITY OF PATRAS)

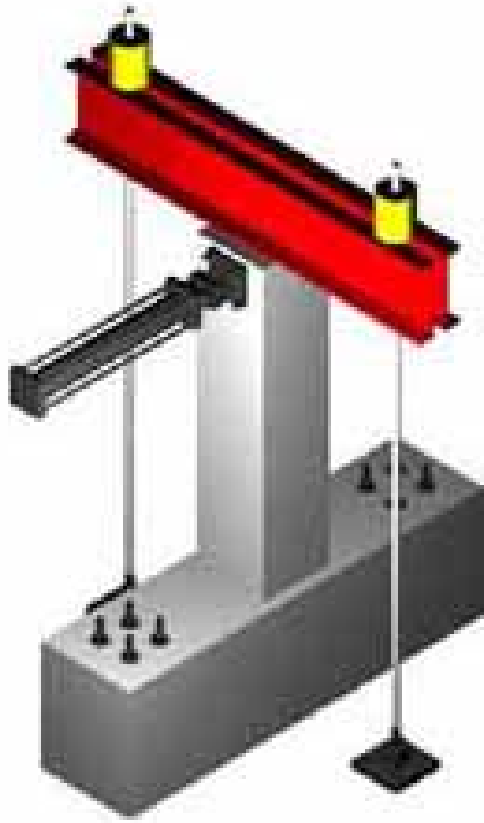



**Damage to a specimen with shotcrete and dowels**



**Damage to a specimen with poured concrete, smooth interface without dowels**



**Addition of a new concrete layer  
to the top of a cantilever slab**



# Beam strengthened with a new concrete layer

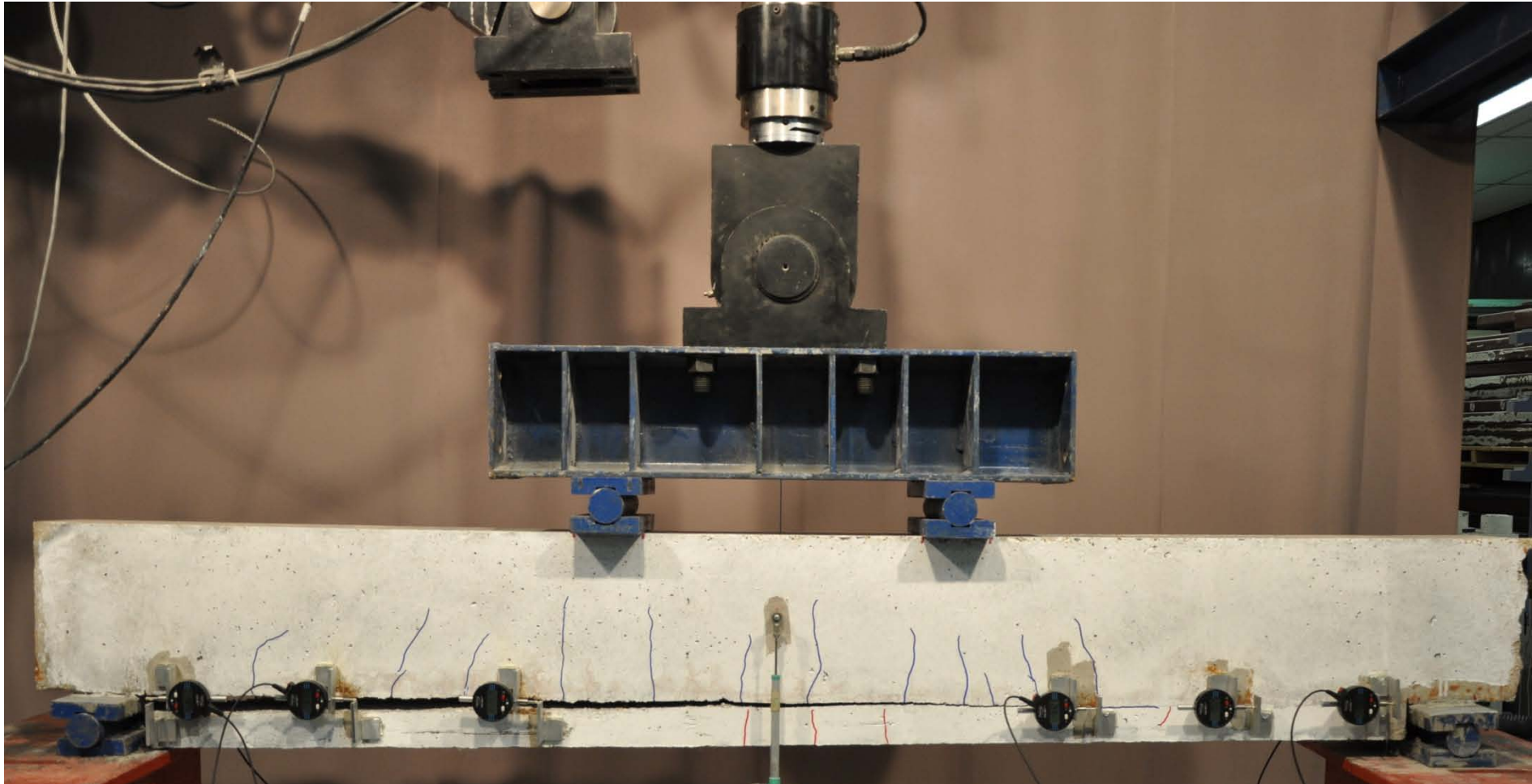

**Interface failure due to inadequate anchorage of the new bars at the supports**

# BASIC DESIGN CONSIDERATION

Repaired/Strengthened Element



Multi – Phased Element



Composite Element



Influence of Interface Connection

# DESIGN FRAMEWORK

Into the existing framework for new constructions  
Supplemented by:

- Control of Sufficient Connection Between Contact Surfaces
- Determination of Strength and Deformation Capacity of the Strengthened Element
  - **As a Composite** Element (Multi-Phased Element)

# CONTROL OF A SUFFICIENT CONNECTION BETWEEN CONTACT SURFACES

$$S_d \leq R_d$$

$$V_{S_d}^{interface} \leq V_{R_d}^{interface}$$

**Interface Shear Force**  $\leq$  **Interface Shear Resistance**

# INTERFACE SHEAR FORCES: $V_{sd}^{interface}$

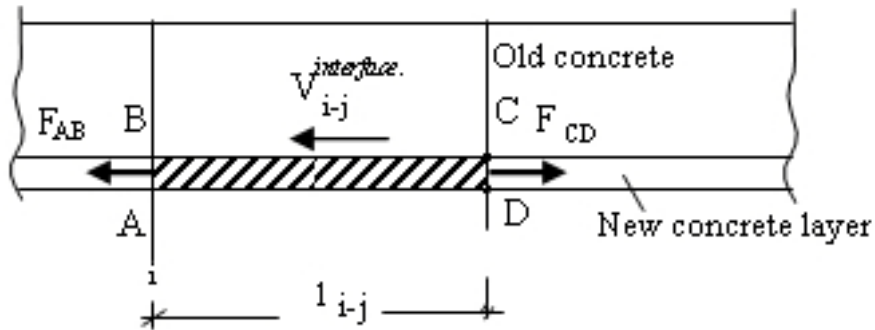

$$V_{i-j}^{interface} = F_{AB} - F_{CD}$$

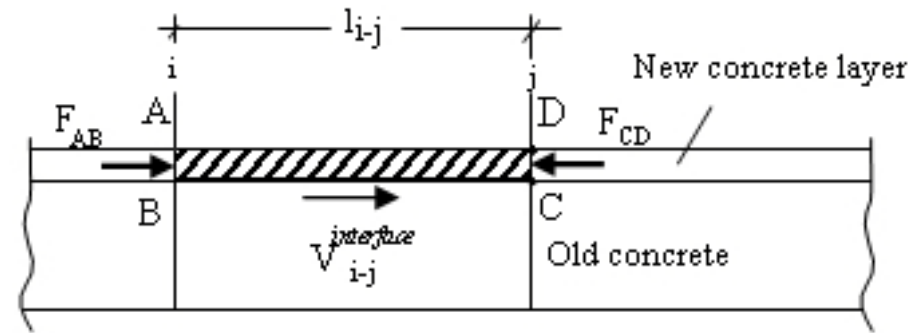

$$V_{i-j}^{interface} = F_{AB} - F_{CD}$$

(a) strengthening in the tensile zone

(b) strengthening in the compressive zone

# Technological guidelines for repairs and strengthening:



ΙΝΣΤΙΤΟΥΤΟ ΟΙΚΟΝΟΜΙΑΣ ΚΑΤΑΣΚΕΥΩΝ

## ΠΡΟΣΩΡΙΝΕΣ ΕΘΝΙΚΕΣ ΤΕΧΝΙΚΕΣ ΠΡΟΔΙΑΓΡΑΦΕΣ (ΠΕΤΕΠ)

Εργασίες Αποκατάστασης Ζημιών Κατασκευών  
από τον Σεισμό και λοιπούς Βλαπτικούς Παράγοντες

Τεχνικό Επιμελητήριο Ελλάδας  
Αθήνα 2008



## **Roughening by sandblasting**



**Use of a scabblers to improve frictional resistance by removing the exterior weak skin of the concrete to expose the aggregate**





**Concrete jacketing in practice**





**Total jacket**

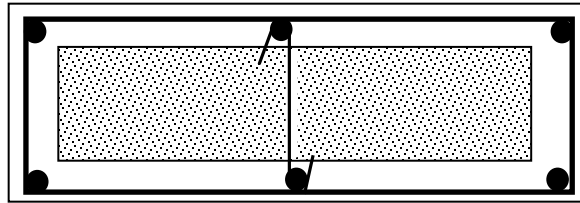

**Inserting intermediate links in sections with a high aspect ratio**

# Inserting intermediate stirrups in square sections

**NO**

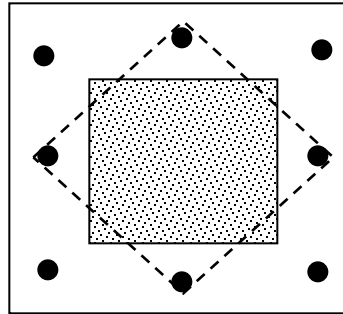

**YES**

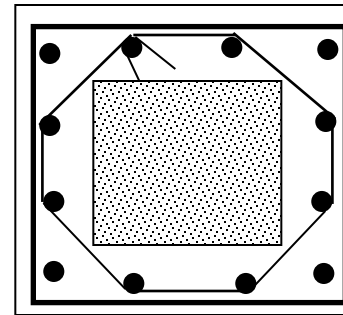

135° bend to form hooks

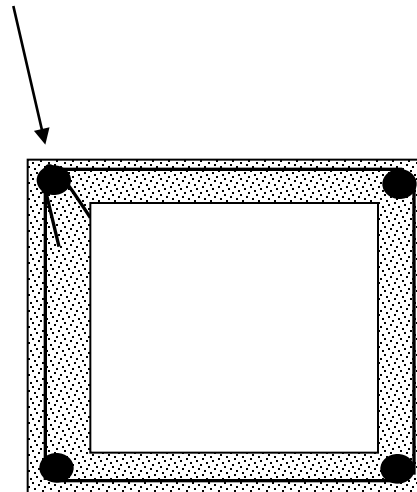



**Bar buckling due to stirrup ends opening**



**Welding of jacket's stirrup ends**

# INTERFACE SHEAR RESISTANCE: $V_{Rd}^{interface}$

## Mechanisms

- Friction and Adhesion
- Dowel Action
- Clamping Action
- Welded Connectors



# UNREINFORCED INTERFACES

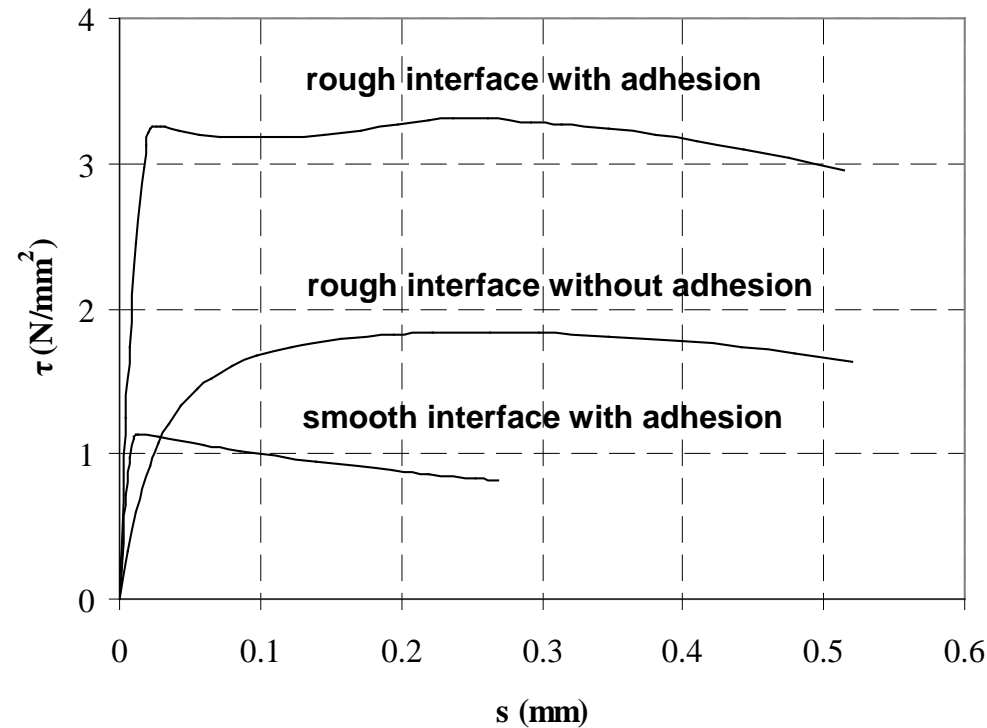

(CEB Bul. No. 162, 1983)

Concrete-to-concrete adhesion

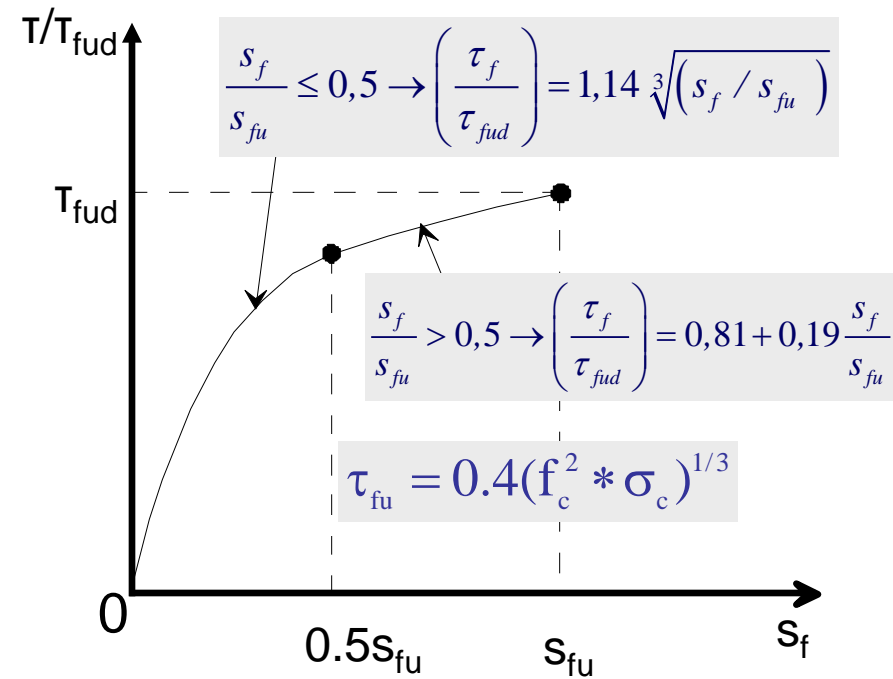

(GRECO, 2012)

Roughened interface concrete-to-concrete friction

# REINFORCED INTERFACES

## Additional Friction

When a Steel Bar Crosses an Interface, a Clamping Action May Occur if:

- Surface of Existing Concrete has been Roughened
- The Steel Bar is Adequately Anchored

(Tassios and Vintzeleou, 1987)

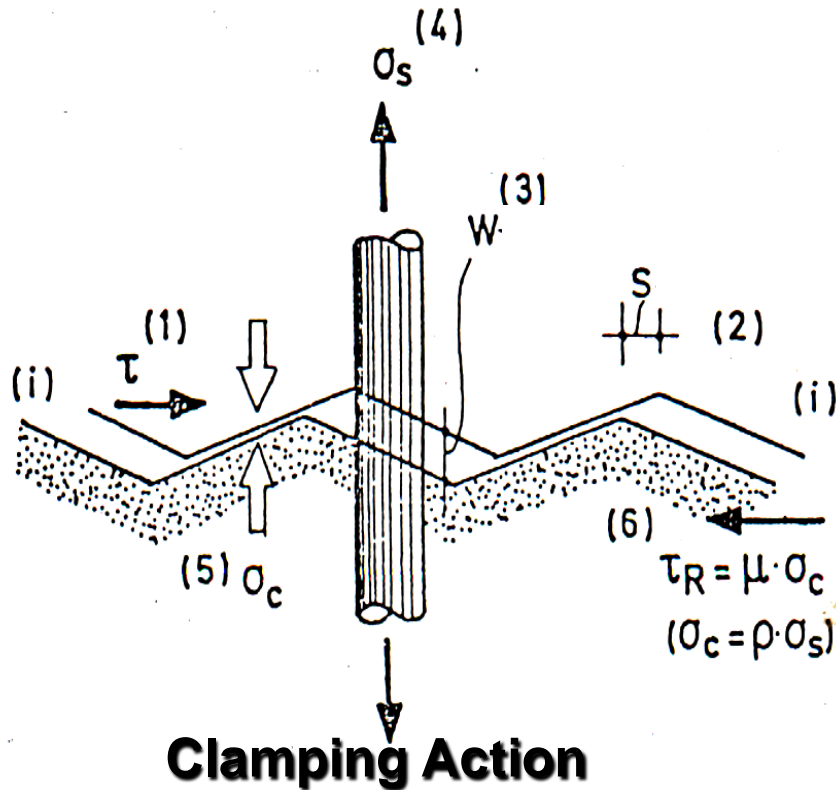

(1) When Shear Stress is Applied

(2) Slip Occurs

(3) Contact Surface Opens (one surface rides up over the other due to roughness)

(4) Tensile Strength is Activated in the Steel Bar

(5) Compression Stress ( $\sigma_c$ ) is Mobilized at the Interface

(6) Frictional Resistance is Activated

# Reinforced Interfaces

## Frictional resistance

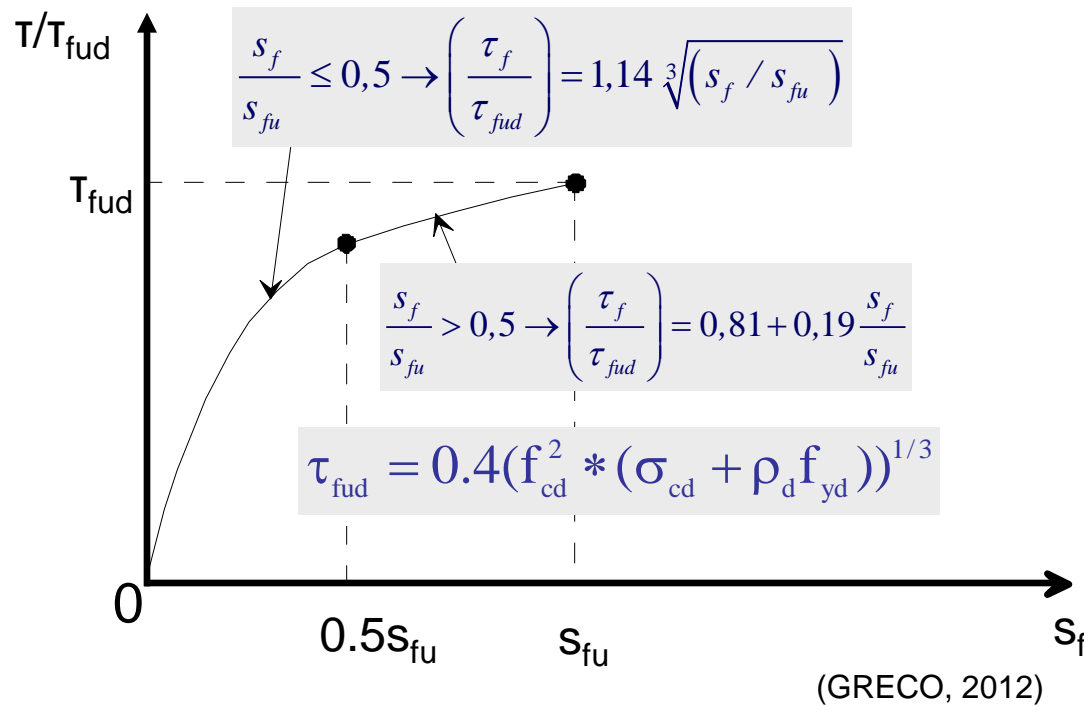

# Reinforced Interfaces

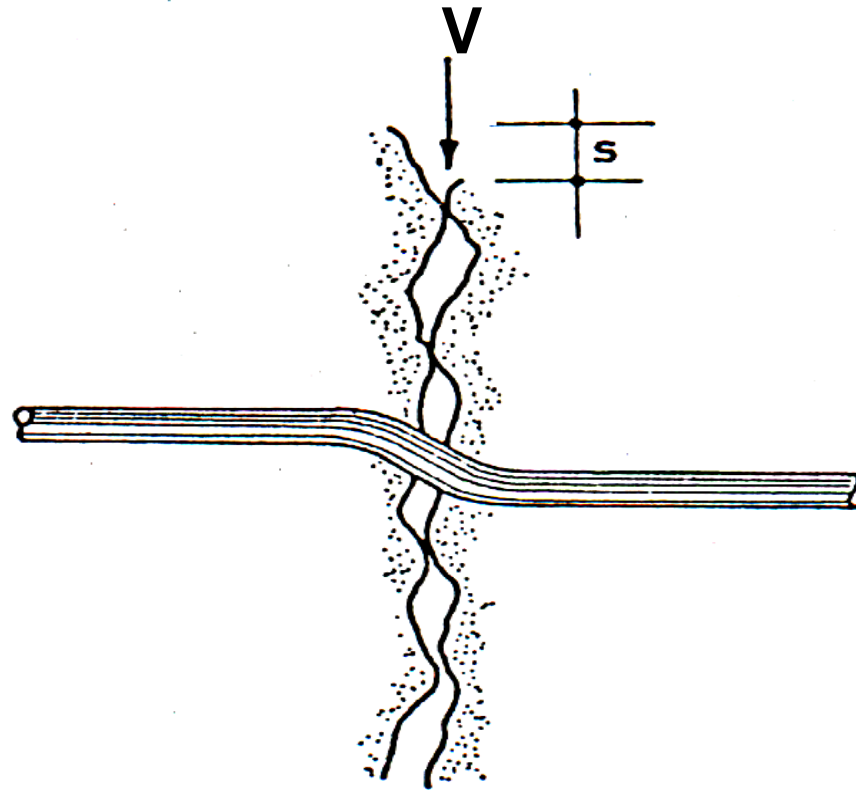

**Dowel action**

# Shear Resistance

for Dowel Action as a function of the interface slip

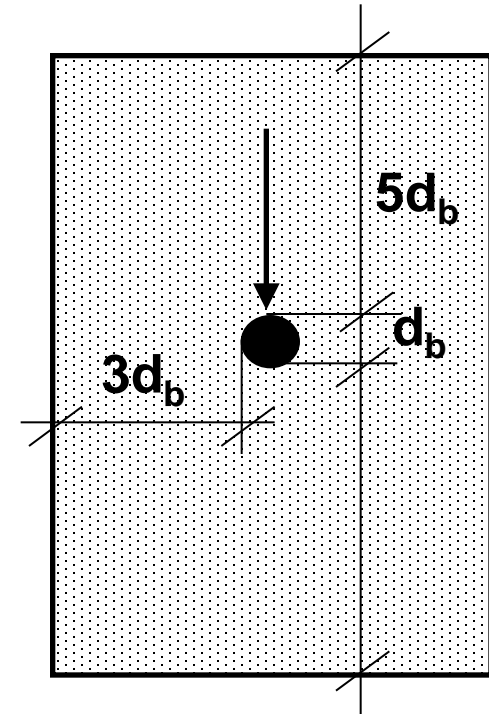
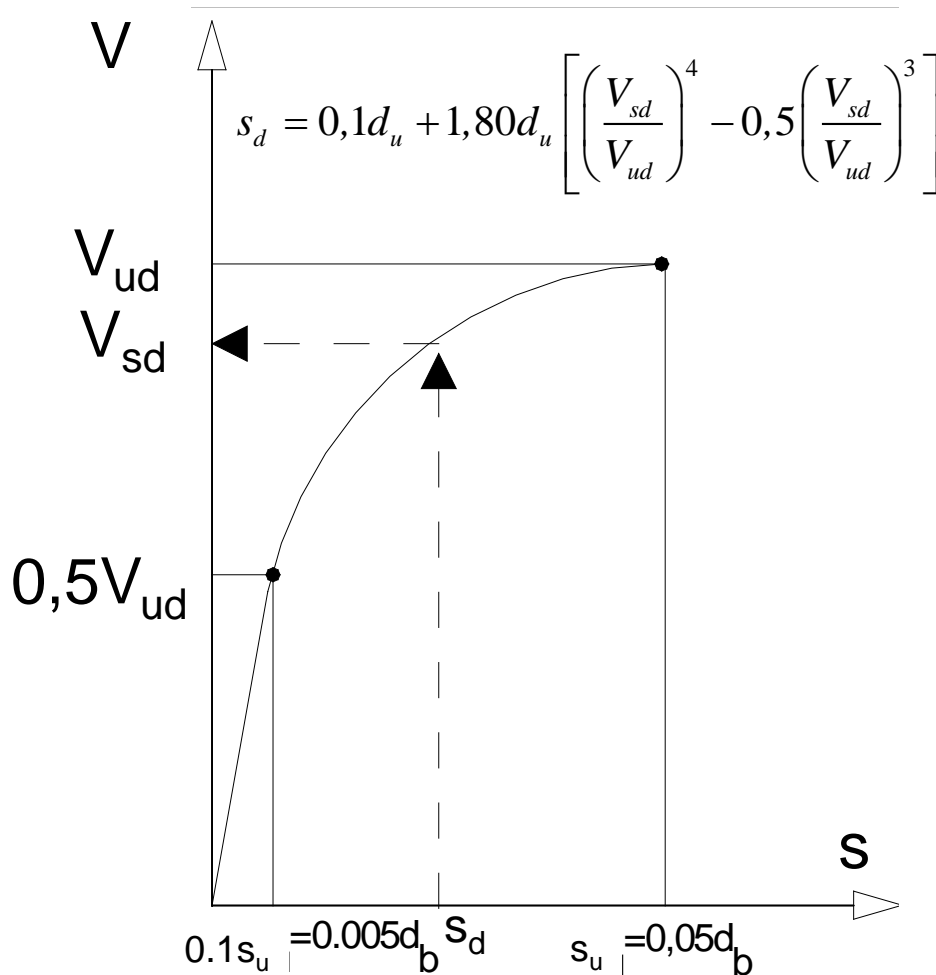

**A minimum concrete cover is necessary for full activation of dowel action**

$$V_{ud} = 1.3 d_b^2 \sqrt{f_c f_y}$$

## Use of steel dowels and roughening the surface of an original column



- Most popular in practice to achieve a sufficient connection at the interface

# Reinforced Interfaces

## Bent Connecting Steel Bars



# Bent Bar Model

(Tassios, 2004)

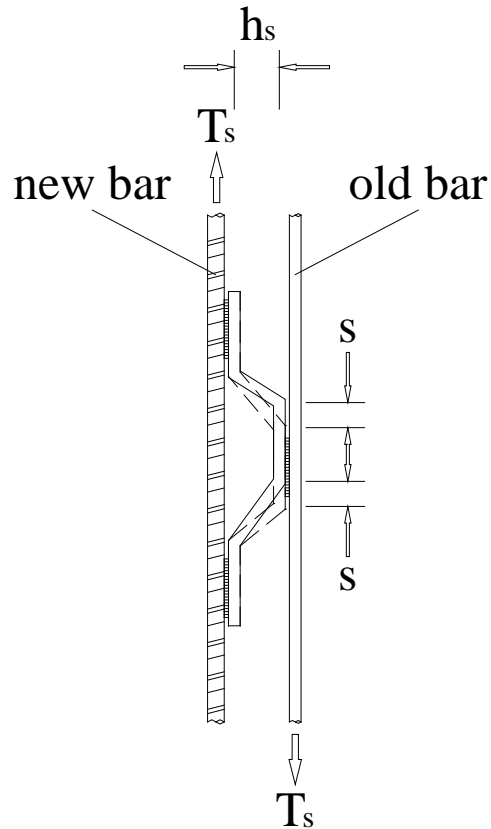

When  $s$  occur at the interface one leg of the bent bar is elongated by  $s/\sqrt{2}$  the other is shortened

→ Tensile and Compressive Leg Stresses are mobilized:

$$\epsilon_{sb} = \frac{s/\sqrt{2}}{\sqrt{2}h_s} = \frac{s}{2h_s} \quad \text{and} \quad \sigma_{sb} = E_s \frac{s}{2h_s} \leq f_{yb}$$

→ Force is Transferred between Reinforcements:

$$T_s = A_{sb} * E_s (s/\sqrt{2}h_s) \leq T_{sy} = \sqrt{2}A_{sb} f_{yb}$$



## Force Transferred – Interface Slippage

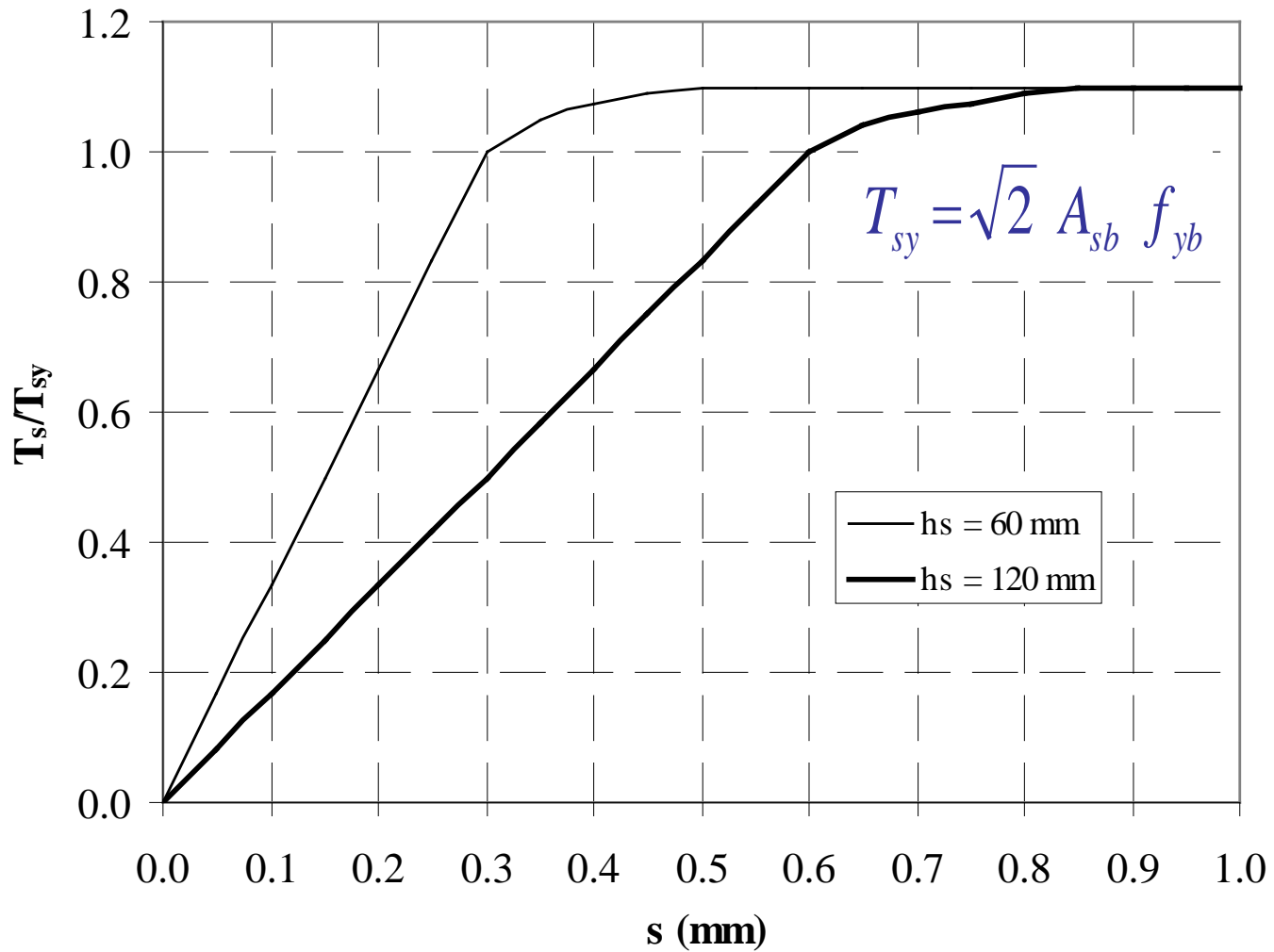

**Mechanism is mobilized for very small Slippage**

# Superposition of shear resistance mechanisms

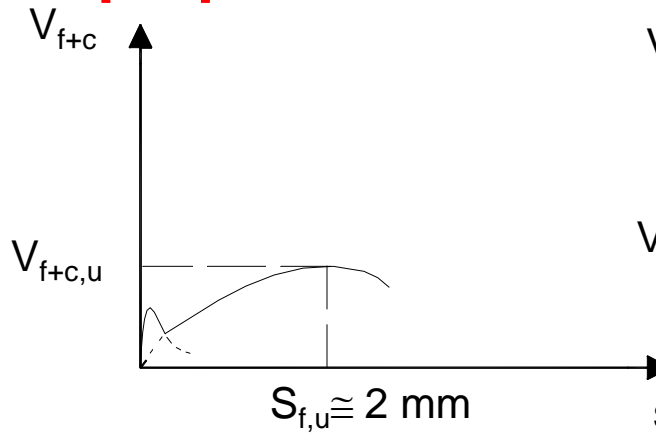

a) Adhesion and friction

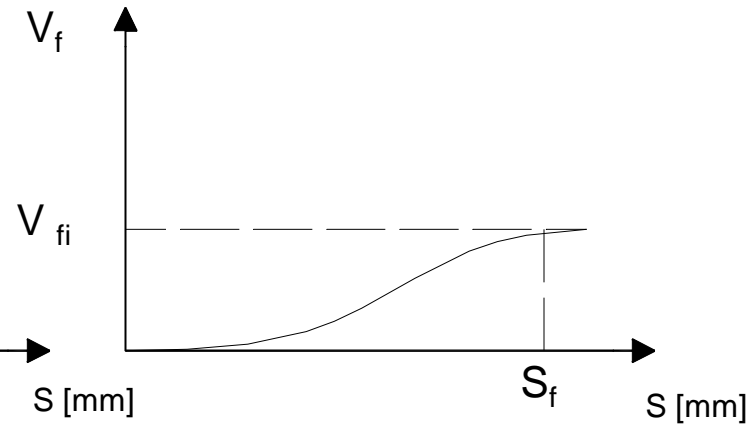

b) Clamping action

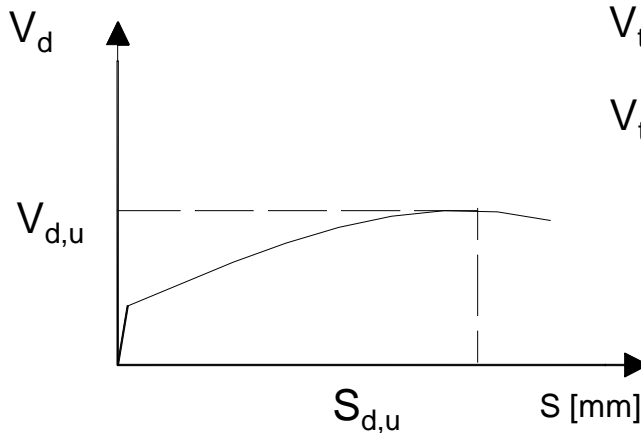

c) Dowel action

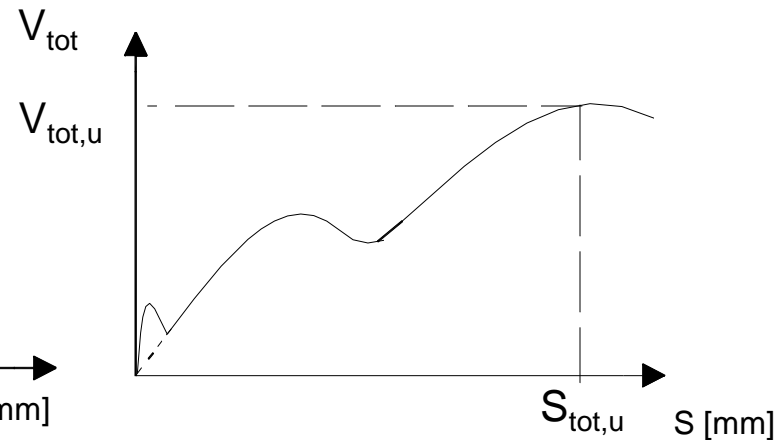

d) Superposition of all actions

$$V_{tot} = \beta_D V_d + \beta_f V_f$$

P

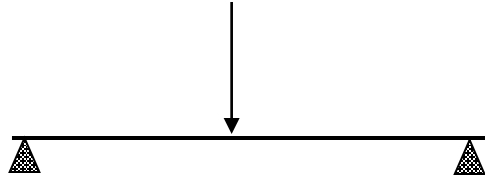

### Full interaction

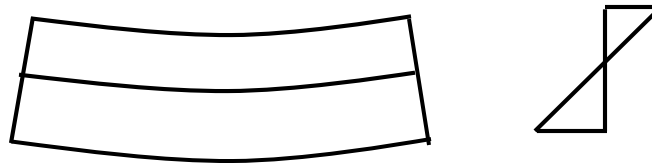

### Partial interaction

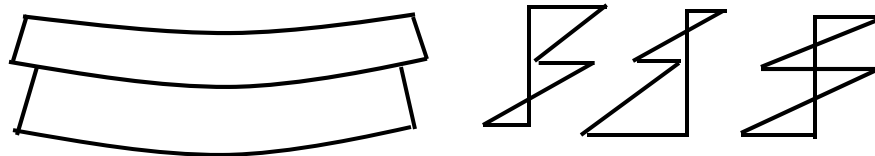

### Independent action

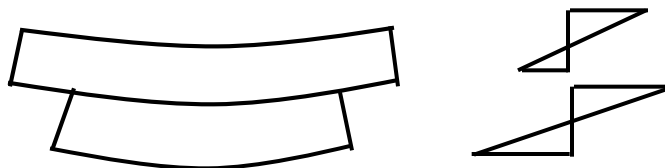

# CAPACITY OF MULTI-PHASED ELEMENT

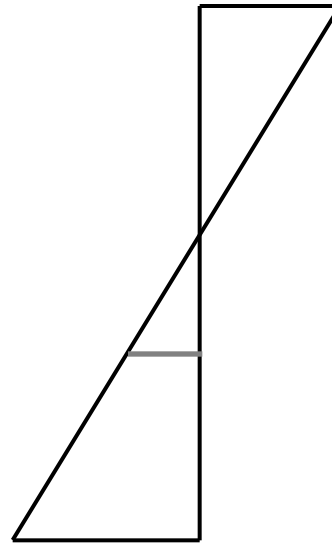
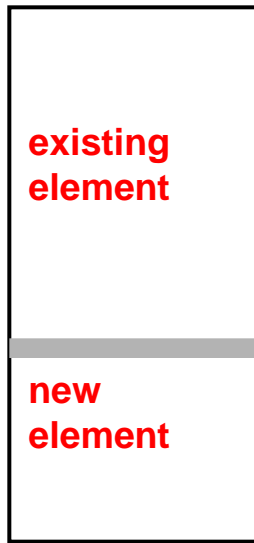

(a)

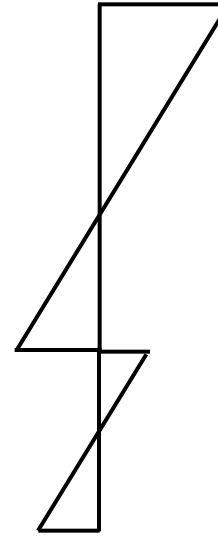

(b)

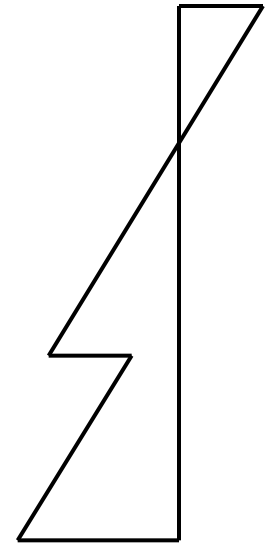

(c)

**Distribution of Strain With Height of Cross Section**

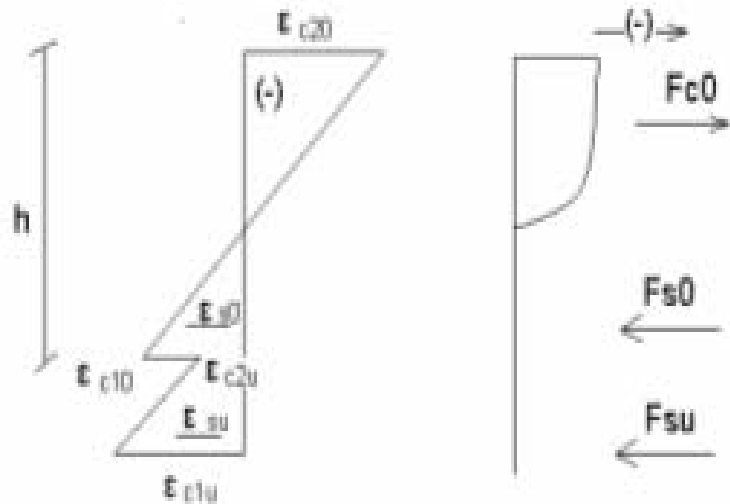
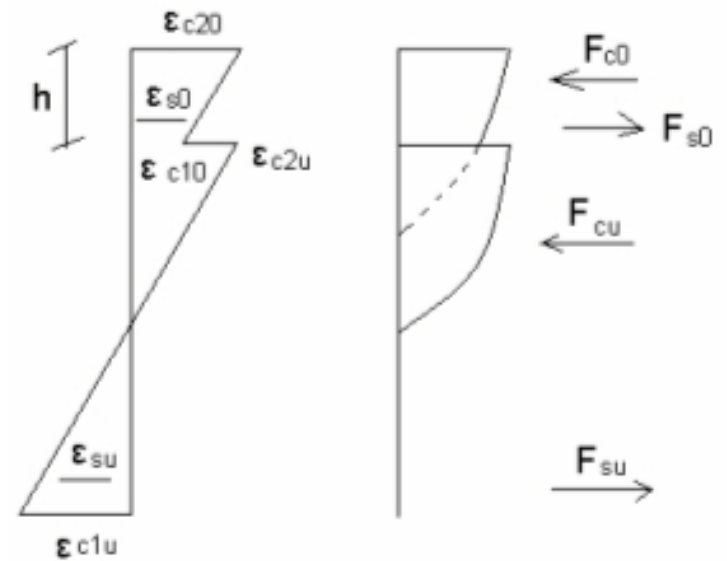
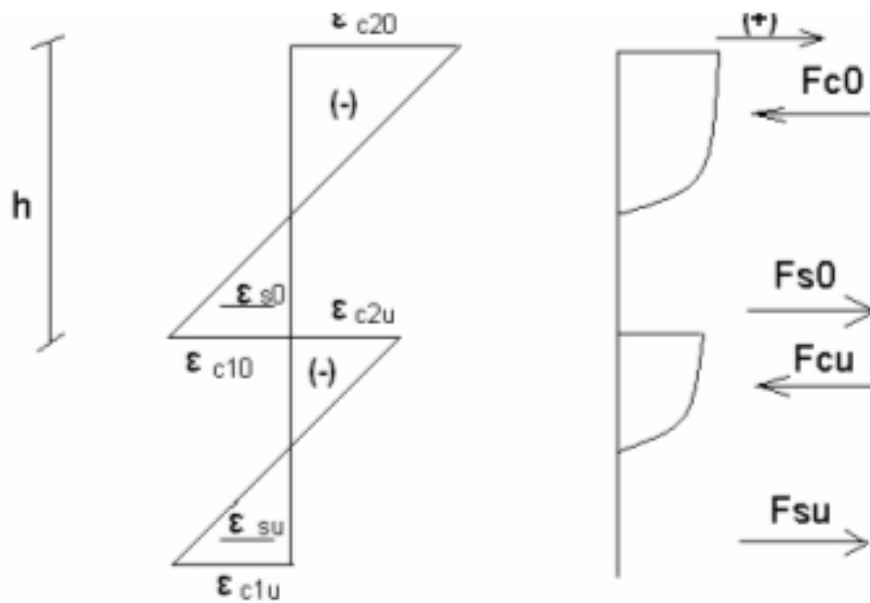

Possible strain and stress distributions

# CAPACITY CURVES

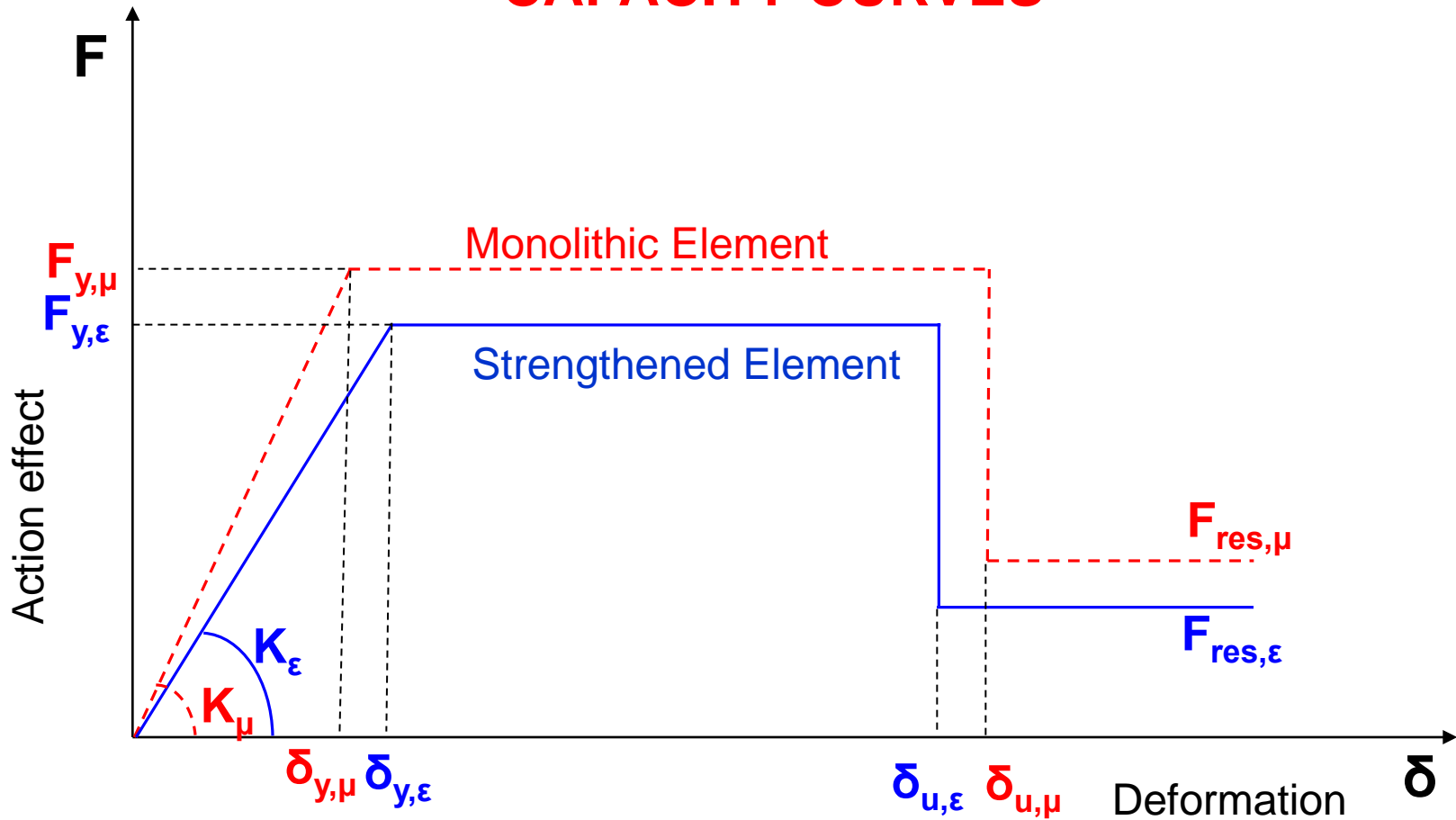

$$K_\kappa = \frac{K_\epsilon}{K_\mu} \quad K_r = \frac{F_{y,\epsilon}}{F_{y,\mu}} \quad K_\omega = \frac{\delta_{y,\epsilon}}{\delta_{y,\mu}} \quad K_\delta = \frac{\delta_{u,\epsilon}}{\delta_{u,\mu}}$$

# MONOLITHIC BEHAVIOUR FACTORS

## ■ For the Stiffness:

$$k_k = \frac{\text{the stiffness of the strengthened element}}{\text{the stiffness of the monolithic element}}$$

## ■ For the Resistance:

$$k_r = \frac{\text{the strength of the strengthened element}}{\text{the strength of the monolithic element}}$$

## ■ For the Displacement:

$$k_{\delta_y} = \frac{\text{the displacement at yield of the strengthened element}}{\text{the displacement at yield of the monolithic element}}$$

$$k_{\delta_y} = \frac{\text{the ultimate displacement of the strengthened element}}{\text{the ultimate displacement of the monolithic element}}$$

$$(EI)_{\text{strengthened}} = k_k (EI)_M$$

$$R_{\text{strengthened}} = k_r R_M$$

$$\delta_{i,\text{strengthened}} = k_{\delta_i} \delta_{i,M}$$



**Addition of a new concrete layer  
to the top of a cantilever slab**



# Monolithic Factors

- Approximations according to G.C.S.I.

For slabs:

$$k_k = 0,85$$

$$k_r = 0,95$$

$$k_{\theta y} = 1,15$$

$$k_{\theta u} = 0,85$$

For concrete jackets:

$$k_k = 0,80$$

$$k_r = 0,90$$

$$k_{\theta y} = 1,25$$

$$k_{\theta u} = 0,80$$

For other elements:

$$k_k = 0,80$$

$$k_r = 0,85$$

$$k_{\theta y} = 1,25$$

$$k_{\theta u} = 0,75$$

# Monolithic Factors

## Influence of Interface Connecting Conditions in Case of Concrete Jackets

Monolithic coefficient of stiffness

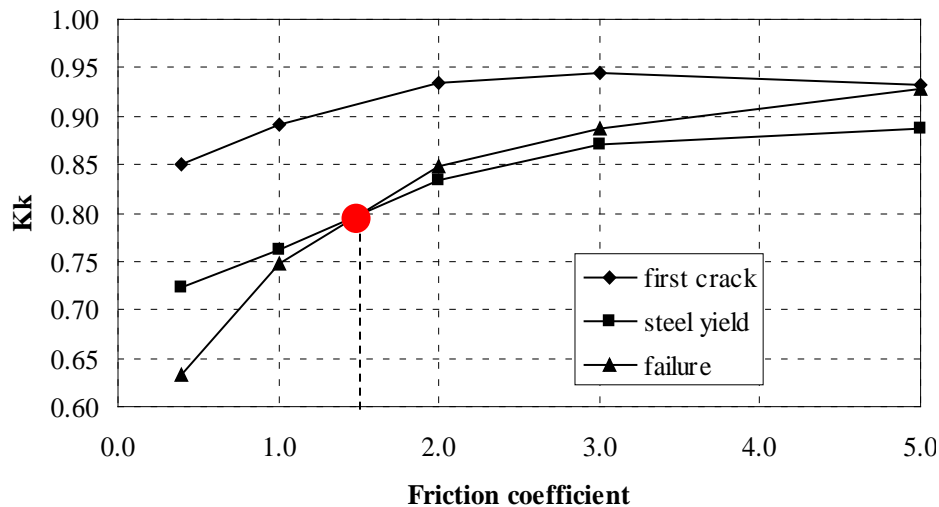

Monolithic coefficient of resistance

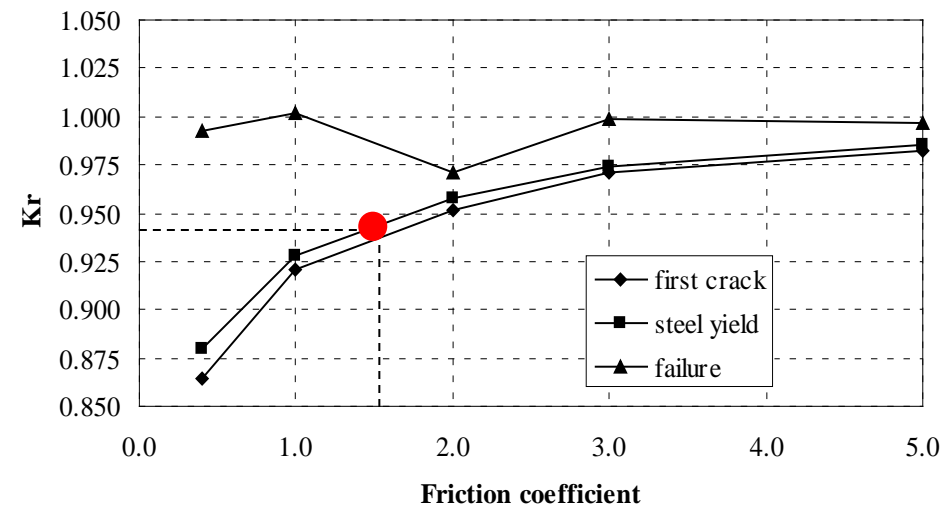

For  $\mu=1.4$        $k_k = 0.80$  and  $k_r = 0.94$

$k_k = 0.70$  and  $k_r = 0.80$

(EC8, Part 1.4)

$k_k = 0.80$  and  $k_r = 0.90$

(G.C.S.I.)